

2024

**WDB**

[www.grupawdb.pl](http://www.grupawdb.pl)

**KATALOG**

**AKCESORIA DO  
BRAM I OGRODZEŃ**

**AKCESORIA  
OGRODOWE  
I BALKONOWE**

**ZAŚLEPKI  
PLASTIKOWE**

**SKRZYNKI  
NA LISTY**

**TARCZE  
DO METALU**

**DRUT  
SPAVALNICZY**

**AUTOMATYKA  
DO BRAM**

**SYSTEMY DRZWI  
PRZESUWNYCH**

**PLANDEKI**

1

## AKCESORIA DO BRAM I OGRODZEŃ

STR. 3-36

accessories for gates and fences | pgs. 3-36  
 Zubehöre für Tore und Zäune | s. 3-36  
 фурнитура для ворот и заборов | стр. 3-36



2

## AKCESORIA OGRODOWE I BALKONOWE

STR. 37-49

garden and balcony accessories | pgs. 37-49  
 Garten und Balkon Zubehör | s. 37-49  
 садовые и балконные аксессуары | стр. 37-49

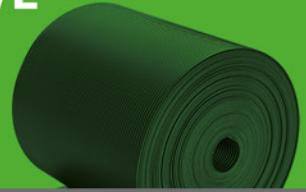

3

## ZAŚLEPKI PLASTIKOWE

STR. 50-53

end caps | pgs. 50-53  
 Abdeckkappen | s. 50-53  
 заглушки | стр. 50-53



4

## SKRZYNKI NA LISTY

STR. 54-62

mail boxes | pgs. 54-62  
 Briefkästen | s. 54-62  
 почтовые ящики | стр. 54-62



5

## TARCZE DO METALU

STR. 63-65

discs | pgs. 63-65  
 Trennscheiben | s. 63-65  
 диски | стр. 63-65



6

## DRUT SPAWALNICZY

STR. 66-67

welding wires | pgs. 66-67  
 Schweissdraht | s. 66-67  
 сварочная проволока | стр. 66-67



7

## AUTOMATYKA DO BRAM

STR. 68-69

automation for gates | pgs. 68-69  
 Torautomatik | s. 68-69  
 автоматика для ворот | стр. 68-69



8

## SYSTEMY DRZWI PRZESUWNYCH

STR. 70-75

Barn Door hardware kit | pgs. 70-75  
 Schiebetürsystem – Barn Door | s. 70-75  
 Раздвижная система для дверей Barn Door | стр. 70-75



9

## PLANDEKI

STR. 76-78

Tarpaulins | pgs. 76-78  
 Abdeckplanen | s. 76-78  
 Тенты | стр. 76-78



# SPIIS TREŚCI

TABLE OF CONTENT / INHALTSÜBERSICHT / ОГЛАВЛЕНИЕ

## AKCESORIA DO BRAM I OGRODZEŃ

ACCESSORIES FOR GATES AND FENCES / ZUBEHÖRE FÜR TORE UND ZÄUNE / ФУРНИТУРА ДЛЯ ВОРОТ И ЗАБОРОВ .....	<b>3</b>
<b>Komplety wózków do bram</b> Cantilever gate carriages sets / Laufrollenbocksätze / Комплекты роликовых опор.....	4
<b>Wózki do bram</b> Cantilever gate carriages / Laufrollenböcke / Роликовые опоры .....	6
<b>Akcesoria do bram</b> Accessories for gates / Zubehöre für Tore / Фурнитура для ворот .....	9
<b>Listwy zębate</b> Gear racks / Zahnstangen / Зубчатые рейки .....	16
<b>Zawiasy</b> Hinges / Scharniere / Петли.....	17
<b>Systemy podwieszane</b> Hanging doors system / Hängende Schiebetorsysteme / Подвесная фурнитура .....	22
<b>Rolki jezdne</b> Gate wheels / Torrollen / Ролики .....	24
<b>Klamki, pochwyt</b> Door handles / Türdrücker und Griffe / Дверные ручки .....	25
<b>Zamki, kasety</b> Locks, boxes / Schlösser, Kästen / Замки, корпуса .....	27
<b>Elektrozaczepy</b> Electric locks / Elektrische Türöffner / Электромагнитные защелки .....	33
<b>Rygle, zasuw</b> Latches / Riegel / Ригели и задвижки .....	34

## AKCESORIA OGRODOWE I BALKONOWE

GARDEN AND BALCONY ACCESSORIES / GARTEN UND BALKON ZUBEHÖR / САДОВЫЕ И БАЛКОННЫЕ АКЦЕССУАРЫ .....	<b>37</b>
--	-----------

## ZAŚLEPKI PLASTIKOWE

END CAPS / ABDECKKAPPEN / ЗАГЛУШКИ .....	<b>50</b>
--	-----------

## SKRZYŃKI NA LISTY

MAIL BOXES / BRIEFKÄSTEN / ПОЧТОВЫЕ ЯЩИКИ .....	<b>54</b>
---	-----------

## TARCZE DO METALU

DISCS / TRENNSCHEIBEN / ДИСКИ .....	<b>63</b>
-------------------------------------	-----------

## DRUT SPAWALNICZY

WELDING WIRES / SCHWEISSDRAHT / СВАРОЧНАЯ ПРОВОЛОКА .....	<b>66</b>
---	-----------

## AUTOMATYKA DO BRAM

AUTOMATION FOR GATES / TORAUTOMATIK / АВТОМАТИКА ДЛЯ ВОРОТ .....	<b>69</b>
--	-----------

## SYSTEMY DRZWI PRZESUWNYCH

BARN DOOR HARDWARE KIT / SCHIEBETÜRSYSTEM – BARN DOOR / РАЗДВИЖНАЯ СИСТЕМА ДЛЯ ДВЕРЕЙ BARN DOOR .....	<b>70</b>
--	-----------

## PLANDEKI

TARPAULINS, ABDECKPLANEN, ТЕНТЫ .....	<b>76</b>
---------------------------------------	-----------

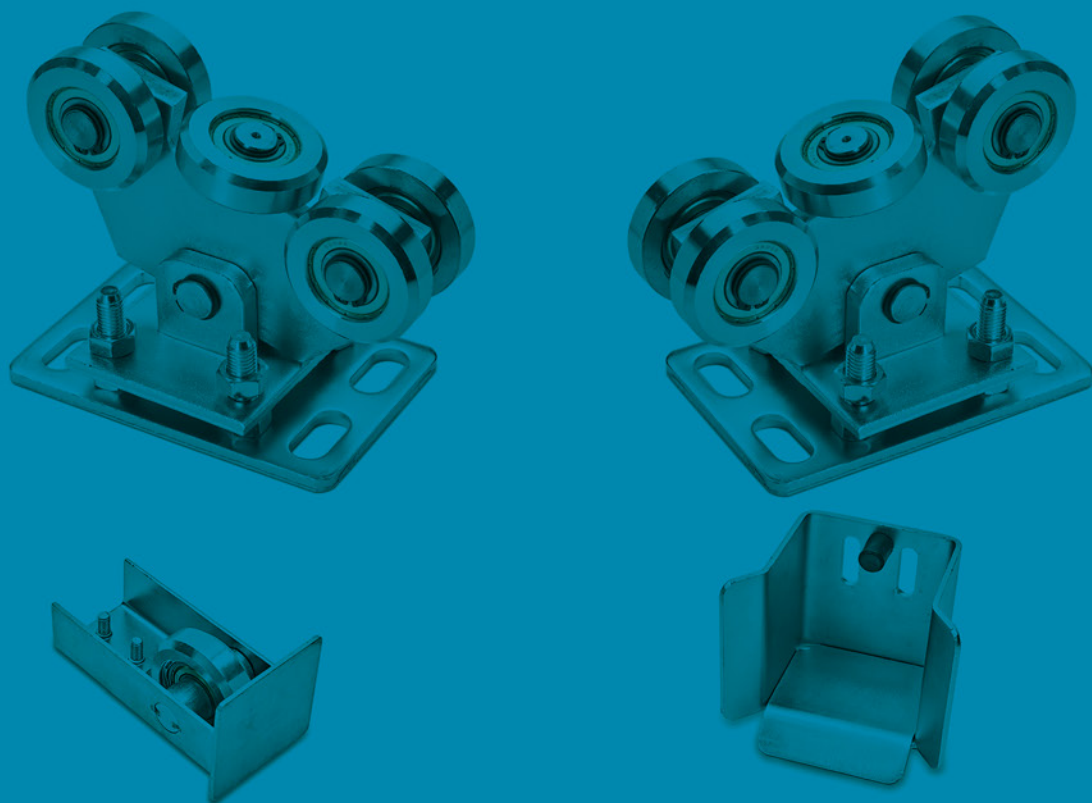

# AKCESORIA DO BRAM I OGRODZEŃ

ACCESSORIES FOR GATES AND FENCES  
ZUBEHÖRE FÜR TORE UND ZÄUNE  
ФУРНИТУРА ДЛЯ ВОРОТ И ЗАБОРОВ

1

**Komplet wózków z akcesoriami [60.003.K60]**

Carriages set with accessories / Schiebetorsystemset / Комплект опор с аксессуарами



- » 2 × wózek jezdny do profilu 60 × 60 × 3,5 mm [60.003.60]  
2 × cantilever gate carriage for profile 60 × 60 × 3,5 mm  
2 × Laufrollbock für Profil 60 × 60 × 3,5 mm  
2 × роликовая опора для профиля 60 × 60 × 3,5 мм
- » uchwyt najazdu [60.020.60]  
cup for rail  
Auflaufschuh  
улавливатель
- » rolka najazdowa [60.011.60]  
guide wheel  
Auflaufrolle  
концевой ролик

**Komplet wózków z akcesoriami [60.003.K70]**

Carriages set with accessories / Schiebetorsystemset / Комплект опор с аксессуарами



- » 2 × wózek jezdny do profilu 70 × 70 × 4 mm [60.003.70]  
2 × cantilever gate carriage for profile 70 × 70 × 4 mm  
2 × Laufrollbock für Profil 70 × 70 × 4 mm  
2 × роликовая опора для профиля 70 × 70 × 4 мм
- » uchwyt najazdu [60.020]  
cup for rail  
Auflaufschuh  
улавливатель
- » rolka najazdowa [60.011.70]  
guide wheel  
Auflaufrolle  
концевой ролик

**Komplet wózków z akcesoriami [60.003.K80]**

Carriages set with accessories / Schiebetorsystemset / Комплект опор с аксессуарами

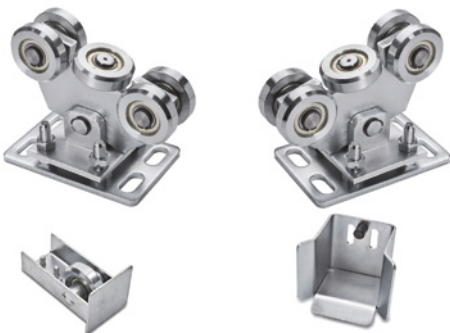

- » 2 × wózek jezdny do profilu 80 × 80 × 5 mm [60.003]  
2 × cantilever gate carriage for profile 80 × 80 × 5 mm  
2 × Laufrollbock für Profil 80 × 80 × 5 mm  
2 × роликовая опора для профиля 80 × 80 × 5 мм
- » uchwyt najazdu [60.020]  
cup for rail  
Auflaufschuh  
улавливатель
- » rolka najazdowa [60.011.80]  
guide wheel  
Auflaufrolle  
концевой ролик

**Komplet wózków z akcesoriami [60.007.K]**

Carriages set with accessories / Schiebetorsystemset / Комплект опор с аксессуарами



- » 2 × wózek jezdny do profilu 80 × 80 × 5 mm [60.007]  
2 × cantilever gate carriage for profile 80 × 80 × 5 mm  
2 × Laufrollbock für Profil 80 × 80 × 5 mm  
2 × роликовая опора для профиля 80 × 80 × 5 мм
- » uchwyt najazdu [60.020]  
cup for rail  
Auflaufschuh  
улавливатель
- » rolka najazdowa [60.011.80]  
guide wheel  
Auflaufrolle  
концевой ролик

## Komplet wózków z akcesoriami [60.003.KP70]

Carriages set with accessories / Schiebetorsystemset / Комплект опор с аксессуарами



- » 2 × wózek jezdny do profilu 70 × 70 × 4 mm [60.003.70.01]  
2 × cantilever gate carriage for profile 70 × 70 × 4 mm  
2 × Laufrollenbock für Profil 70 × 70 × 4 mm  
2 × роликовая опора для профиля 70 × 70 × 4 мм
- » uchwyt najazdu [60.020]  
cup for rail  
Auflaufschuh  
улавливатель
- » rolka najazdowa [60.011.70]  
guide wheel  
Auflaufrolle  
концевой ролик

## Komplet wózków z akcesoriami [60.003.KP80]

Carriages set with accessories / Schiebetorsystemset / Комплект опор с аксессуарами



- » 2 × wózek jezdny do profilu 80 × 80 × 5 mm [60.003.01]  
2 × cantilever gate carriage for profile 80 × 80 × 5 mm  
2 × Laufrollenbock für Profil 80 × 80 × 5 mm  
2 × роликовая опора для профиля 80 × 80 × 5 мм
- » uchwyt najazdu [60.020]  
cup for rail  
Auflaufschuh  
улавливатель
- » rolka najazdowa [60.011.80]  
guide wheel  
Auflaufrolle  
концевой ролик

## Komplet wózków z akcesoriami [60.007.01.K]

Carriages set with accessories / Schiebetorsystemset / Комплект опор с аксессуарами



- » 2 × wózek jezdny do profilu 80 × 80 × 5 mm [60.007.01]  
2 × cantilever gate carriage for profile 80 × 80 × 5 mm  
2 × Laufrollenbock für Profil 80 × 80 × 5 mm  
2 × роликовая опора для профиля 80 × 80 × 5 мм
- » uchwyt najazdu [60.020]  
cup for rail  
Auflaufschuh  
улавливатель
- » rolka najazdowa [60.011.80]  
guide wheel  
Auflaufrolle  
концевой ролик

## Wózek jezdny 60

Cantilever gate carriages 60 / Laufrollenböcke 60 / Роликовые опоры 60

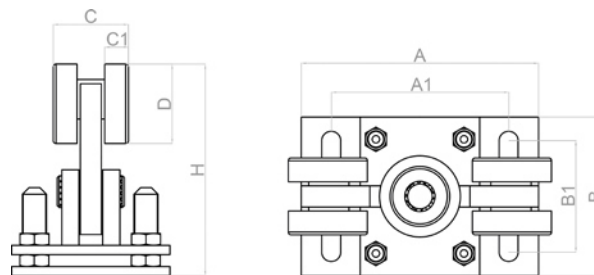

	A [mm]	A1 [mm]	B [mm]	B1 [mm]	C [mm]	C1 [mm]	D [mm]	H [mm]
60.003.60	145	115	100	60	45	13	51	150

## Wózek jezdny 70

Cantilever gate carriages 70 / Laufrollenböke 70 / Роликовые опоры 70

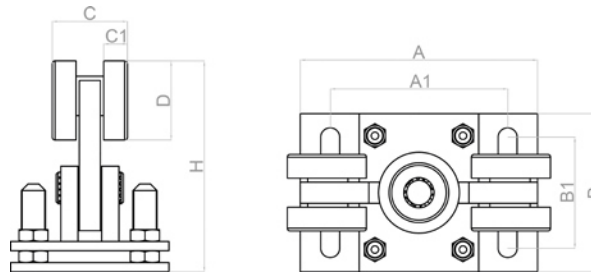

	A [mm]	A1 [mm]	B [mm]	B1 [mm]	C [mm]	C1 [mm]	D [mm]	H [mm]
60.003.70	180	140	120	60	57	18	60	150 - 172

## Wózek jezdny 80

Cantilever gate carriages 80 / Laufrollenböke 80 / Роликовые опоры 80

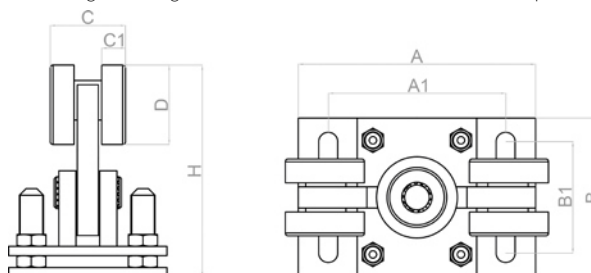

	A [mm]	A1 [mm]	B [mm]	B1 [mm]	C [mm]	C1 [mm]	D [mm]	H [mm]
60.003	180	140	120	60	61	17	68	154 - 176

## Wózek jezdny 80

Cantilever gate carriages 80 / Laufrollenböke 80 / Роликовые опоры 80

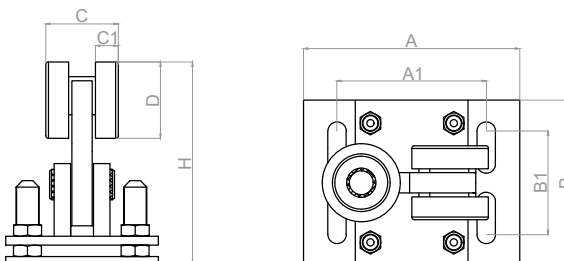

	A [mm]	A1 [mm]	B [mm]	B1 [mm]	C [mm]	C1 [mm]	D [mm]	H [mm]
60.004	180	140	120	60	61	17	68	145

## Wózek jezdny 80

Cantilever gate carriages 80 / Laufrollenböke 80 / Роликовые опоры 80

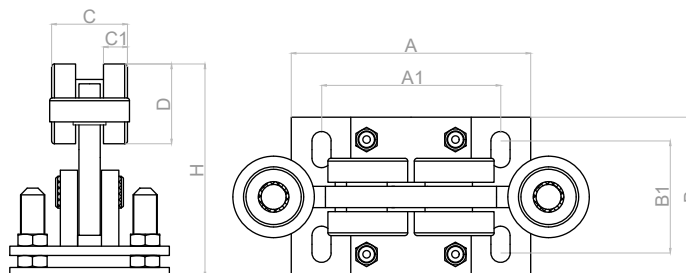

	A [mm]	A1 [mm]	B [mm]	B1 [mm]	C [mm]	C1 [mm]	D [mm]	H [mm]
60.006	180	140	120	60	61	17	68	153 - 170

### Wózek jezdny 80

Cantilever gate carriages 80 / Laufrollenböke 80 / Роликовые опоры 80

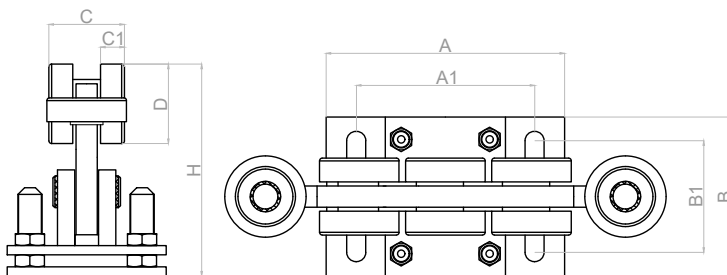

	A [mm]	A1 [mm]	B [mm]	B1 [mm]	C [mm]	C1 [mm]	D [mm]	H [mm]
60.009.08	180	140	120	60	61	17	68	153 - 170

### Wózek jezdny 80

Cantilever gate carriages 80 / Laufrollenböke 80 / Роликовые опоры 80

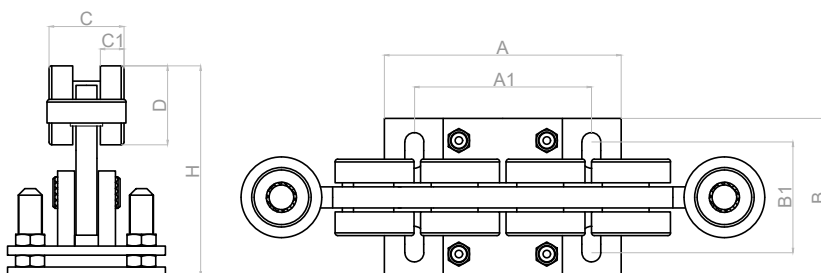

	A [mm]	A1 [mm]	B [mm]	B1 [mm]	C [mm]	C1 [mm]	D [mm]	H [mm]
60.009.10	180	140	120	60	61	17	68	153 - 170

### Wózek jezdny 80

Cantilever gate carriages 80 / Laufrollenböke 80 / Роликовые опоры 80

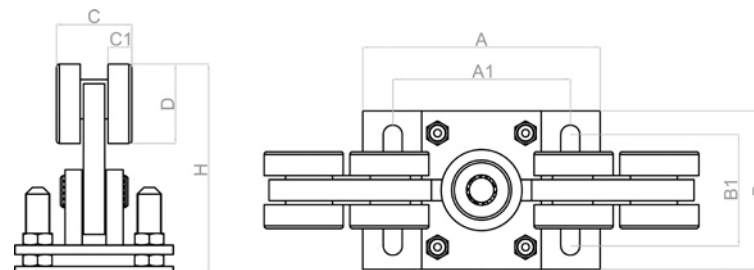

	A [mm]	A1 [mm]	B [mm]	B1 [mm]	C [mm]	C1 [mm]	D [mm]	H [mm]
60.007	180	140	120	60	61	17	68	153 - 170

### Wózek jezdny 80

Cantilever gate carriages 80 / Laufrollenböke 80 / Роликовые опоры 80

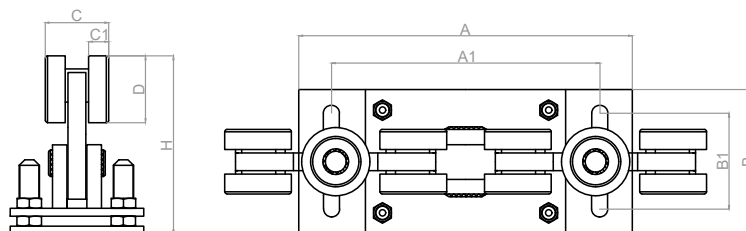

	A [mm]	A1 [mm]	B [mm]	B1 [mm]	C [mm]	C1 [mm]	D [mm]	H [mm]
60.008	300	248	120	60	61	17	68	170 - 185



## Wózek jezdny 70 – rolki poliamidowe

Cantilever gate carriages 70 – polyamide rollers / Laufrollenböke 70 – Polyamidrollen /  
Роликовые опоры 70 – полиамидные ролики

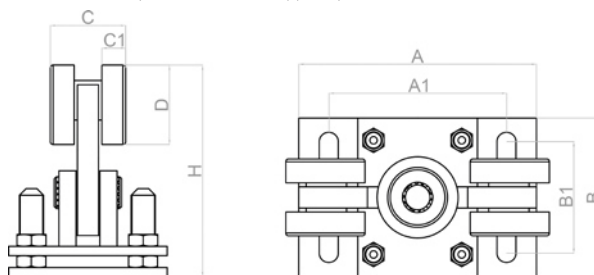

	A [mm]	A1 [mm]	B [mm]	B1 [mm]	C [mm]	C1 [mm]	D [mm]	H [mm]
60.003.70.01	180	140	120	60	57	22	60	150 - 172

## Wózek jezdny 80 – rolki poliamidowe

Cantilever gate carriages 80 – polyamide rollers / Laufrollenböke 80 – Polyamidrollen /  
Роликовые опоры 80 – полиамидные ролики

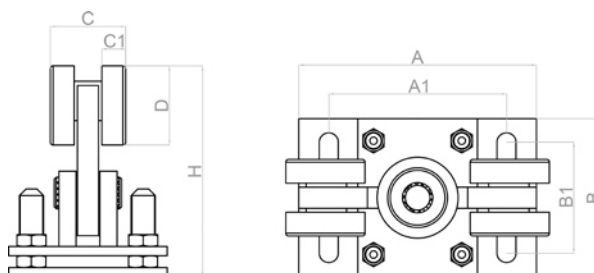

	A [mm]	A1 [mm]	B [mm]	B1 [mm]	C [mm]	C1 [mm]	D [mm]	H [mm]
60.003.01	180	140	120	60	61	22	68	154 - 176

## Wózek jezdny 80 – rolki poliamidowe

Cantilever gate carriages 80 – polyamide rollers / Laufrollenböke 80 – Polyamidrollen /  
Роликовые опоры 80 – полиамидные ролики

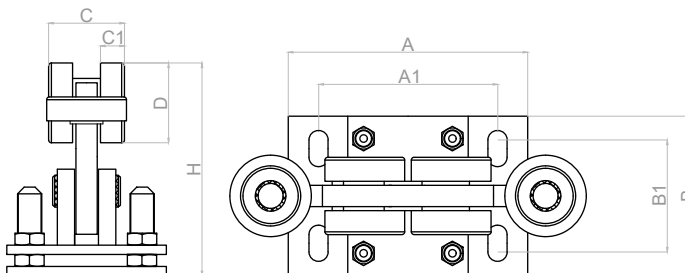

	A [mm]	A1 [mm]	B [mm]	B1 [mm]	C [mm]	C1 [mm]	D [mm]	H [mm]
60.006.01	180	140	120	60	61	17	68	153 - 170

## Wózek jezdny 80 – rolki poliamidowe

Cantilever gate carriages 80 – polyamide rollers / Laufrollenböke 80 – Polyamidrollen /  
Роликовые опоры 80 – полиамидные ролики

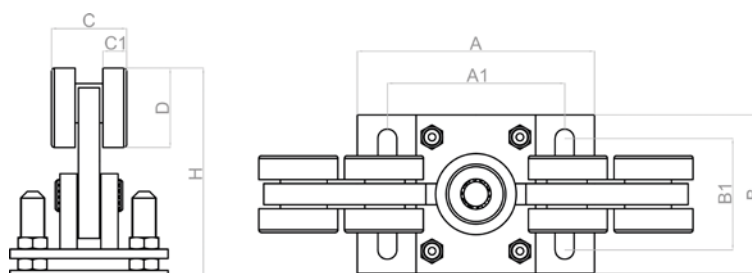

	A [mm]	A1 [mm]	B [mm]	B1 [mm]	C [mm]	C1 [mm]	D [mm]	H [mm]
60.007.01	180	140	120	60	61	22	68	153 - 170

## Rolka najazdowa z zakończeniem

Guide wheel with end cap / Abgeschlossene Auflaufrolle / Концевой ролик

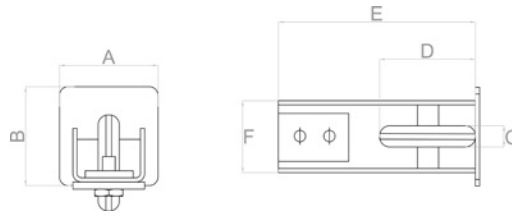

	A [mm]	B [mm]	C [mm]	D [mm]	E [mm]	F [mm]
60.011.60	60	60	15	64	140	51
60.011.70	70	70	17	68	140	51
60.011.80	80	80	17	75	146	62

## Zakończenie profilu

End cap / Torprofilabdeckung / Окончание профиля

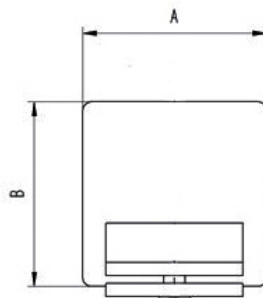

	A [mm]	B [mm]
60.012.60	60	60
60.012.70	70	70
60.012.80	80	80

## Uchwyt najazdu 70/80 z rolkami

Cup for rail 70/80 with rollers / Auflaufschuh 70/80 mit Rollen / Роликовый улавливатель 70/80

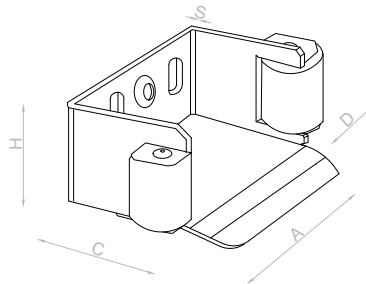

	A [mm]	C [mm]	D [mm]	H [mm]	S [mm]
60.019	100	90	40	80	4

## Uchwyt najazdu 60

Cup for rail 60 / Auflaufschuh 60 / Улавливатель 60

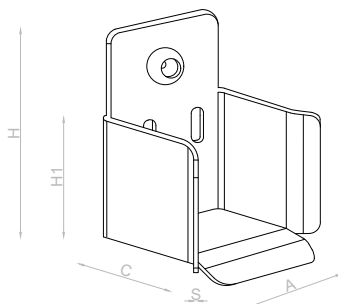

	H [mm]	H1 [mm]	A [mm]	C [mm]	S [mm]
60.020.60	130	78	105	100	4

## Uchwyt najazdu 70/80

Cup for rail 70/80 / Auflaufschuh 70/80 / Улавливатель 70/80

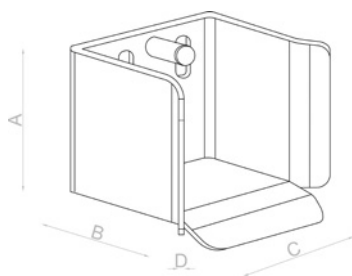

	A [mm]	B [mm]	C [mm]	D [mm]
60.020	100	100	100	4

## Uchwyt najazdu regulowany

Adjustable end stop / Einlaufgabel einstellbar / Регулируемый улавливатель ворот

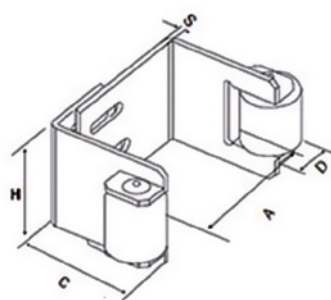

	A [mm]	H [mm]	C [mm]	S [mm]	D [mm]
60.025	55-90	80	95	4	40

## Uchwyt mocujący

End stop bracket / Konsole für Einlaufschuh / Кронштейн улавливателя

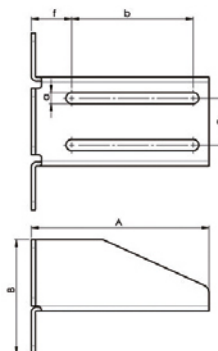

	A [mm]	B [mm]	a [mm]	b [mm]	c [mm]	f [mm]
60.026	174	112	11	119	46	41

## Rolka pionowa

Nylon guide roller / Führungsrolle / Верхний направляющий полимерный ролик

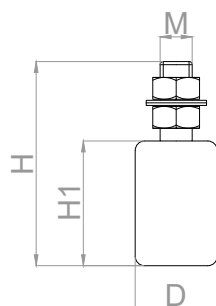

	D [mm]	H [mm]	H1 [mm]	M
60.040	25	75	35	12
60.040.01	30	75	35	12
60.040.02	32	75	35	12
60.040.03	35	75	35	16
60.040.05	40	75	35	16

## Rolka pionowa

Nylon guide roller / Führungsrolle / Верхний направляющий полимерный ролик

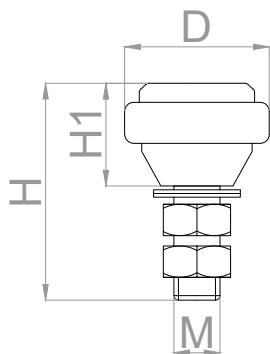

	D [mm]	H [mm]	H1 [mm]	M
60.049	42	80	38	12

## Kątownik

Guiding roll bracket / Führungsrollen Lager / Направляющий кронштейн

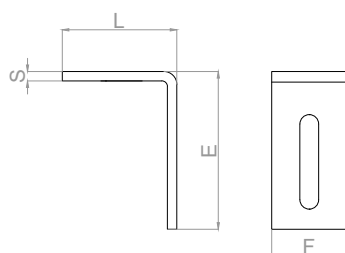

	L [mm]	E [mm]	F [mm]	S [mm]
60.041	61	84	40	5

## Rolka regulowana

Adjustable nylon roller / Rolle einstellbar / Регулируемый ролик

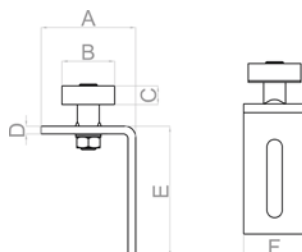

	A [mm]	B [mm]	C [mm]	D [mm]	E [mm]	F [mm]
60.042	61	33	12	5	84	40
60.043	61	35	12	5	84	40

## Uchwyt górny

End stop / Einlaufgabel / Улавливатель ворот

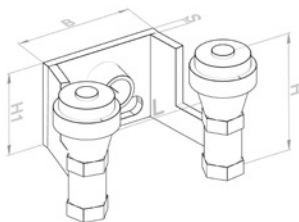

	L [mm]	B [mm]	H [mm]	H1 [mm]	S [mm]
60.022	40	70	76	50	5
60.023	60	65	65	50	5
60.024	80	84	65	50	5

## Prowadzenie górne regulowane

Adjustable gate guide / Laufrollenbock einstellbar / Верхние поддерживающие ролики с регулировкой

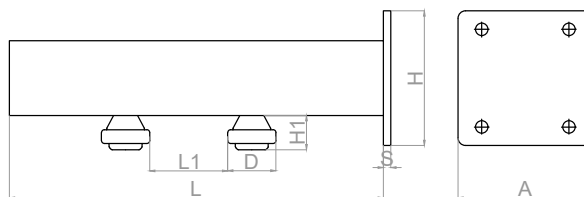

	D [mm]	H1 [mm]	L [mm]	L1 [mm]	A × H [mm]	S [mm]
60.060	43	38	310	0 - 195	100 × 100	4

## Prowadzenie górne regulowane

Adjustable gate guide / Laufrollenbock einstellbar / Верхние поддерживающие ролики с регулировкой

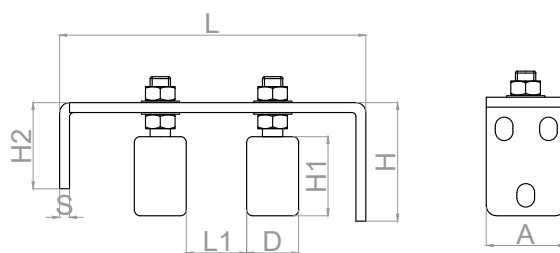

	D [mm]	H1 [mm]	A [mm]	H2 [mm]	H [mm]	L [mm]	L1 [mm]	S [mm]
60.061	30	40	55	40	60	160	33,5 - 80,5	4

## Prowadzenie górne regulowane

Adjustable gate guide / Laufrollenbock einstellbar / Верхние поддерживающие ролики с регулировкой

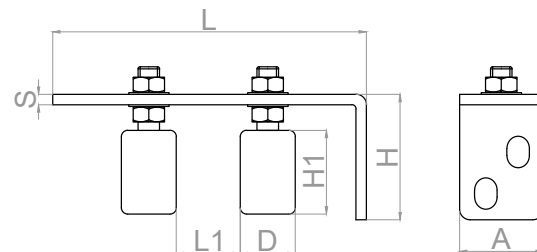

	D [mm]	H1 [mm]	A [mm]	H [mm]	L [mm]	L1 [mm]	S [mm]
60.062	30	40	40	60	150	8 - 68	5

## Prowadzenie górne regulowane

Adjustable gate guide / Laufrollenbock einstellbar / Верхние поддерживающие ролики с регулировкой

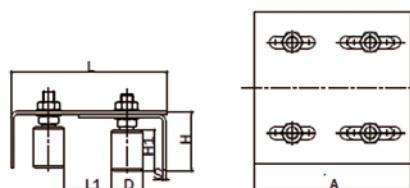
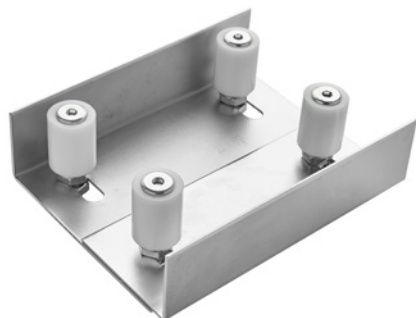

	D [mm]	H1 [mm]	A [mm]	H [mm]	L [mm]	L1 [mm]	S [mm]
60.063	30	40	200	55	164 - 208	26 - 70	2,5

## Stoper do przykręcenia

Fixed end stop / Bodenschlag / Нижний упор

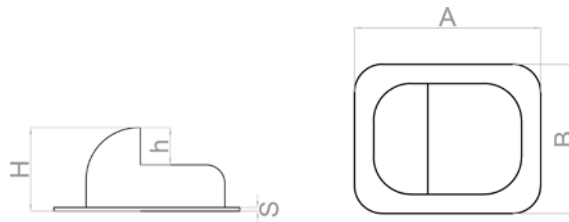

	H [mm]	A × B [mm]	h [mm]	S [mm]
60.091	50	158 × 138	26	2

## Stoper gumowo-metalowy

Fixed end stop / Bodenschlag / Нижний упор

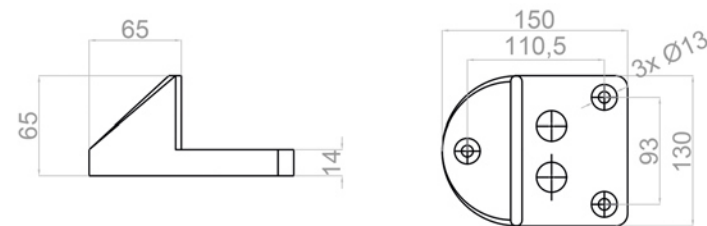

	materiał	kolor	wymiary [mm]
60.092	kauczuk, plastik, stal	czarny	150 × 130 × 65

## Stoper

Fixed end stop / Bodenschlag / Нижний упор

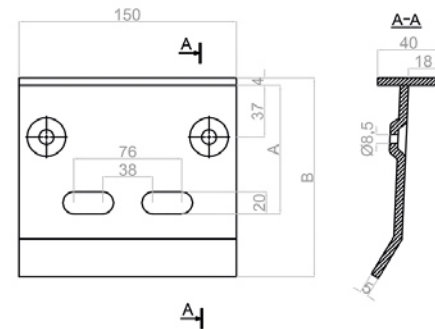

	A [mm]	B [mm]	kolor/ wykończenie
60.095	67	100	ocynk
60.095.01	67	100	czarny
60.096	97	130	ocynk
60.096.01	97	130	czarny

## Nóżka blokująca

Stop / Feststeller / Откидная ножка



	wysokość [mm]	średnica [mm]	kolor
60.097.01	165	14	czarny
60.097.02	220	14	czarny
60.097.03	265	18	czarny
60.097.04	320	25	czarny
60.098.01	165	14	brązowy
60.098.02	220	14	brązowy
60.098.03	265	18	brązowy
60.098.04	320	25	brązowy

## Zderzak zewnętrzny

Gate stopper / Torstopper / Наружный отбойник

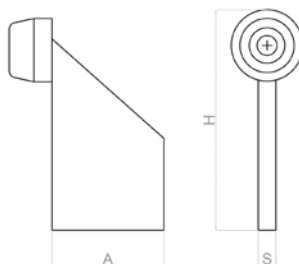

	H [mm]	A [mm]	S [mm]
60.037	100	50	8

## Zderzak zewnętrzny do przykręcenia

Gate stopper / Torstopper / Наружный отбойник

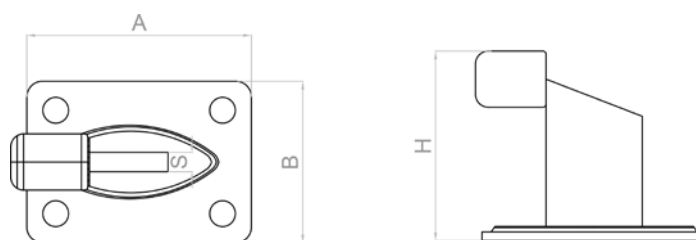

	H [mm]	A × B [mm]	S [mm]
60.038	95	110 × 80	8

## Zderzak zewnętrzny do przykręcenia

Gate stopper / Torstopper / Наружный отбойник

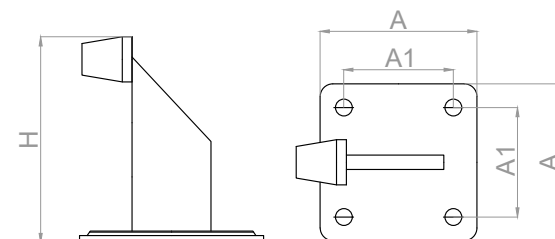

	A [mm]	A1 [mm]	H [mm]
60.039	100	70	142

## Łącznik przęsta ogrodzeniowego

Fencing fastener / Zaunbefestigung / Заборное крепление

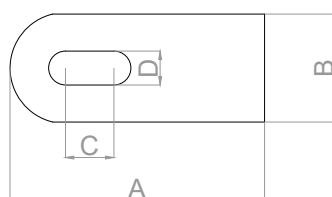

	A [mm]	B [mm]	C [mm]	D [mm]
61.123	35	30	20	9
61.124	40	30	20	9

## Łącznik przęsa ogrodzeniowego

Fencing fastener / Zaunbefestigung / Заборное крепление



	wysokość [mm]	szerokość [mm]	wykończenie
60.120	80	25	ocynk
60.120.7016	80	25	antracyt
60.120.9005	80	25	czarny

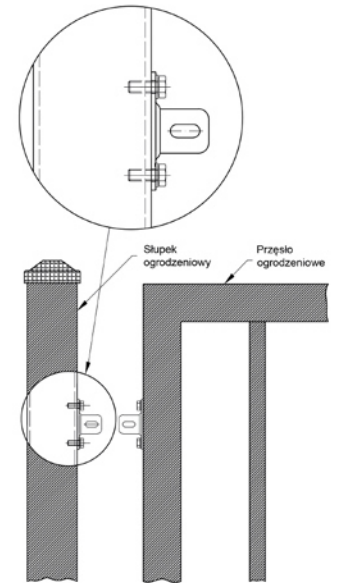
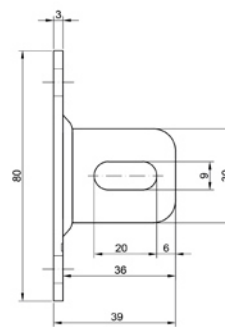
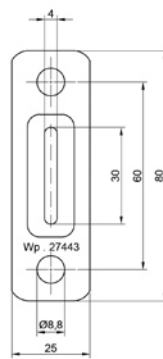



## Listwa zębata stalowa

Metal gear rack / Zahnstange aus Stahl / Зубчатая рейка стальная

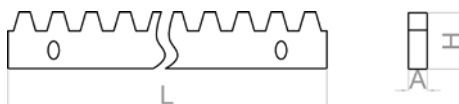
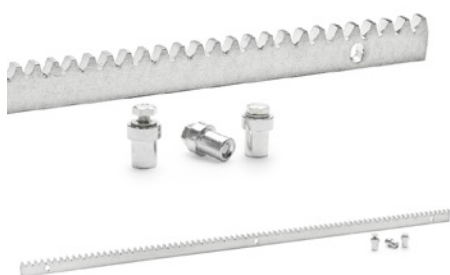

	A [mm]	H [mm]	L [mm]
60.050	10	30	1000
60.051	8	30	1000
60.052	tuleja montażowa do listwy stalowej		

## Listwa zębata poliamidowa z rdzeniem stalowym

Plastic gear rack / Zahnstange aus Kunststoff / Зубчатая рейка пластиковая

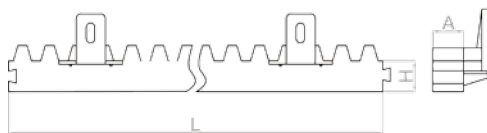
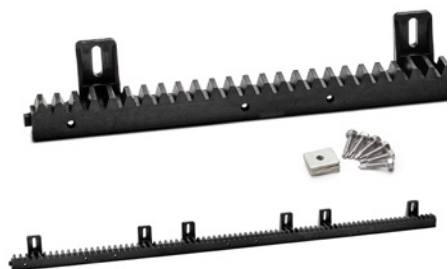

	A [mm]	H [mm]	L [mm]
60.056.01	20	27	1000

## Listwa zębata poliamidowa z rdzeniem stalowym

Plastic gear rack / Zahnstange aus Kunststoff / Зубчатая рейка пластиковая

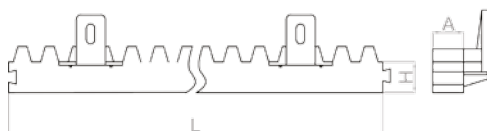
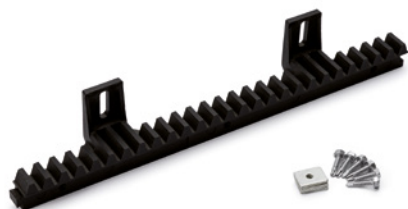

	A [mm]	H [mm]	L [mm]
60.055.01	20	27	3 × 340

## Zawias regulowany długi (jarzmo nieocynkowane)

Adjustable hinge (ungalvanized bracket) / Verstellbares Scharnier (unverzinkter Bogen) / Регулируемая петля длинная (неоцинкованная скоба)

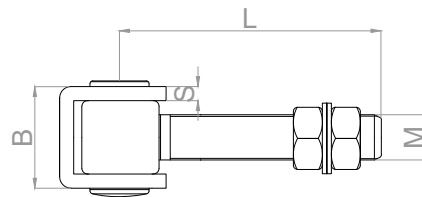

	M	L [mm]	B [mm]	S [mm]
61.002.01	M16	130	35	5
61.003.01	M18	130	40	6
61.004.01	M20	130	40	6

## Zawias do wmurowania

Built-in hinge / Scharnier zum Einbetonieren / Стенная петля

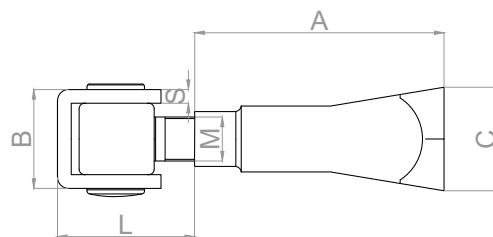

	M	L [mm]	A [mm]	B [mm]	C [mm]	S [mm]
61.005	M16	40 - 64	66	36	38	6
61.006	M20	41 - 58	95	43	40	6

## Zawias regulowany z kotnierzem

Adjustable welding hinge / Verstellbares Scharnier zum Einschweißen / Регулируемая петля приварная

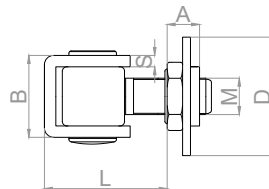
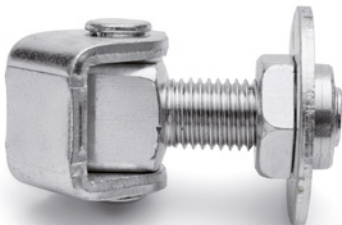

	M	L [mm]	A [mm]	B [mm]	D [mm]	S [mm]
61.011	12	29 - 45	13	26 × 20	40	4
61.012	16	46 - 60	16	36	85	5
61.013	20	44 - 66	17	43	60	6

## Zawias regulowany z kotnierzem (jarzmo nieocynkowane)

Adjustable welding hinge (ungalvanized bracket) / Verstellbares Scharnier zum Einschweißen (unverzinkter Bogen) / Регулируемая петля приварная (неоцинкованная скоба)

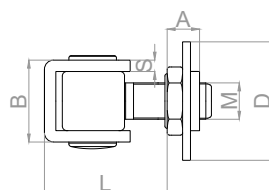
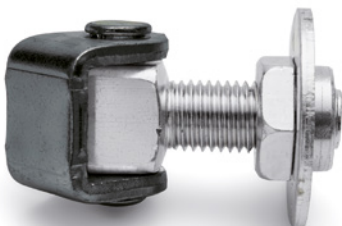

	M	L [mm]	A [mm]	B [mm]	D [mm]	S [mm]
61.011.01	12	29 - 45	13	26 × 20	40	4
61.012.01	16	46 - 60	16	36	85	5
61.013.01	20	44 - 66	17	43	60	6

## Zawias regulowany z szyldem

Adjustable hinge with plate / Verstellbares Scharnier mit Rosette / Регулируемая петля с опорой

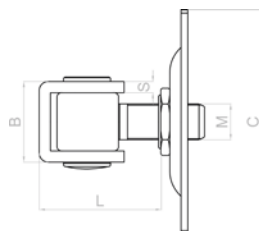

	M	L [mm]	B [mm]	C [mm]	S [mm]
61.018	M16	40 - 60	36	80 × 80	5
61.019	M20	44 - 65	43	100 × 100	6

## Zawias regulowany z szyldem (jarzmo nieocynkowane)

Adjustable hinge with plate (ungalvanized bracket) / Verstellbares Scharnier mit Rosette (unverzinkter Bogen) / Регулируемая петля с опорой (неоцинкованная скоба)

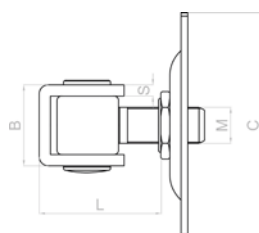

	M	L [mm]	B [mm]	C [mm]	S [mm]
61.018.01	M16	40 - 60	36	80 × 80	5
61.019.01	M20	44 - 65	43	100 × 100	6

## Zawias do wstawiania

Welding hinge / Scharnier zum Einschweißen / Петля приварная

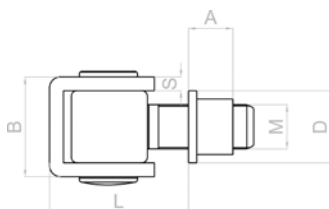
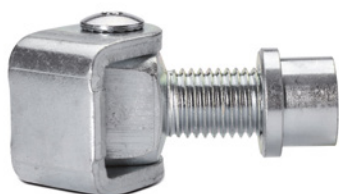

	M	L [mm]	A [mm]	B [mm]	D [mm]	S [mm]
61.025	M12	31 - 47	16	26 × 20	22	4
61.026	M16	40 - 60	16,5	36	25	5
61.027	M20	44 - 68	23	43	31	6

## Zawias do wstawiania (jarzmo nieocynkowane)

Welding hinge (ungalvanized bracket) / Scharnier zum Einschweißen (unverzinkter Bogen) / Петля приварная (неоцинкованная скоба)

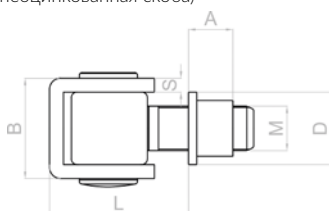

	M	L [mm]	A [mm]	B [mm]	D [mm]	S [mm]
61.025.01	M12	31 - 47	16	26 × 20	22	4
61.026.01	M16	40 - 60	16,5	36	25	5
61.027.01	M20	44 - 68	23	43	31	6

## Zawias regulowany z szyldem

Adjustable hinge with plate / Verstellbares Scharnier mit Rosette / Регулируемая петля с опорой

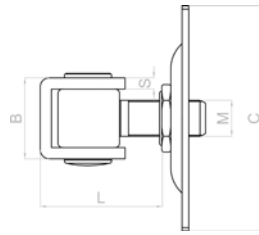

	M	L [mm]	A [mm]	B [mm]	C [mm]	S [mm]
61.047	M12	31 - 47	16	27	75 × 55	4
61.049	M16	40 - 60	18	36	75 × 55	5

## Zawias regulowany z szyldem (jarzmo nieocynkowane)

Adjustable hinge with plate (ungalvanized bracket) / Verstellbares Scharnier mit Rosette (unverzinkter Bogen) / Регулируемая петля с опорой (неоцинкованная скоба)

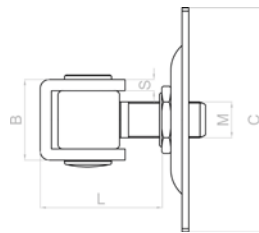

	M	L [mm]	A [mm]	B [mm]	C [mm]	S [mm]
61.047.01	M12	31 - 47	16	27	75 × 55	4
61.049.01	M16	40 - 60	18	36	75 × 55	5

## Zawias regulowany z prostokątnym szyldem

Adjustable hinge with plate / Verstellbares Scharnier mit Rosette / Регулируемая петля с опорой

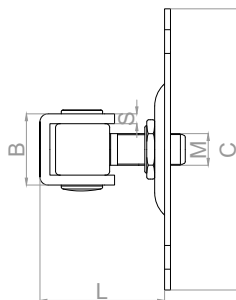

	M	L [mm]	B [mm]	C [mm]	S [mm]	rozstaw otworów
61.050.01	M16	52 - 72	35	75 × 60	5	37 × 52
61.051.01	M16	52 - 72	35	120 × 75	5	52 × 97
61.055.01	M20	60 - 85	40	120 × 85	6	50 × 85
61.056.01	M20	60 - 85	40	160 × 85	6	50 × 125

## Zawias regulowany z prostokątnym szyldem

Adjustable hinge with plate / Verstellbares Scharnier mit Rosette / Регулируемая петля с опорой

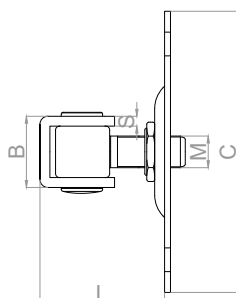

	M	L [mm]	B [mm]	C [mm]	S [mm]
61.070.01	M12	42 - 60	27,5	75 × 37	4
61.071.01	M12	42 - 60	27,5	75 × 37	4

## Zawias regulowany

Adjustable hinge / Verstellbares Scharnier / Регулируемая петля

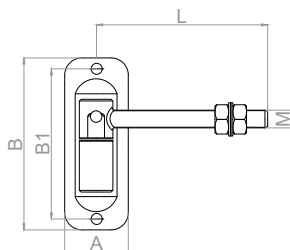

	M	A [mm]	B [mm]	B1 [mm]	L [mm]
61.080	M12	40	150	110	115
61.081	M16	50	180	135	145

## Zawias regulowany

Adjustable hinge / Verstellbares Scharnier / Регулируемая петля

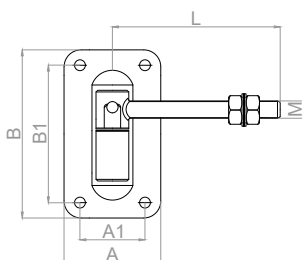

	M	A [mm]	A1 [mm]	B [mm]	B1 [mm]	L [mm]
61.082	M18	85	50	160	125	145

## Zawias regulowany z podstawą

Adjustable hinge with plate / Verstellbares Scharnier mit Rosette / Регулируемая петля с опорой

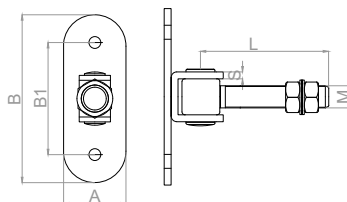
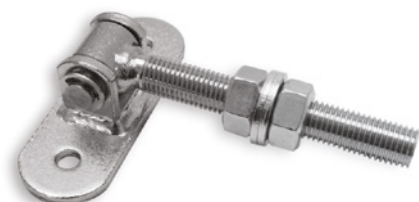

	M	A [mm]	B [mm]	B1 [mm]	L [mm]	S [mm]
61.149	M12	30	90	60	115	3
61.150	M16	40	115	75	130	5
61.151	M18	50	140	90	130	6
61.152	M20	50	140	90	130	6

## Zawias regulowany z podstawą

Adjustable hinge with plate / Verstellbares Scharnier mit Rosette / Регулируемая петля с опорой

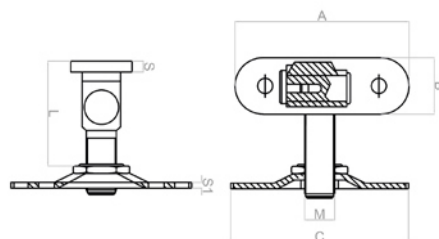
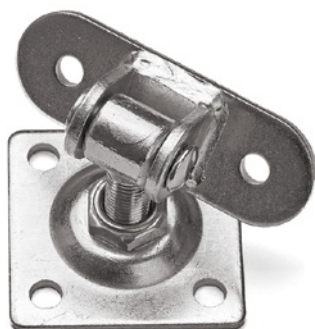

	M	A [mm]	B [mm]	C [mm]	L [mm]	S1 [mm]	S [mm]
61.160	M16	115	40	80 × 80	45 - 65	4	5
61.161	M20	115	40	100 × 100	49 - 70	4	5

## Zawias regulowany z podstawą

Adjustable hinge with plate / Verstellbares Scharnier mit Rosette / Регулируемая петля с опорой

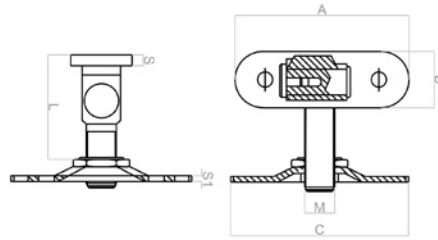

	M	A [mm]	B [mm]	C [mm]	L [mm]	S1 [mm]	S [mm]
61.165	M12	75	37	75 × 37	50 - 70	2,5	4

## Element kąta otwarcia 180°

Opening angle 180° element / Öffnungswinkel 180° Element / Элемент угла открытия 180°

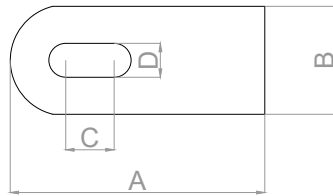

	A [mm]	B [mm]	C [mm]	D [mm]
61.190	100	40	16	17
61.191	120	60	20	20
61.192	120	60	20	22

## Zawias toczony

Welding hinge / Scharnier / Петля точеная приварная

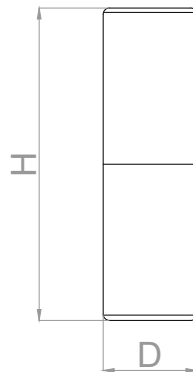

	D [mm]	H [mm]
61.112	12	60
61.116	16	66
61.120	20	70
61.124	24	80
61.127	27	90
61.130	30	100
61.135	35	120
61.140	40	120

## Zawias toczony z kulą

Welding hinge with ball / Scharnier mit Kugel / Петля точеная приварная с шаром

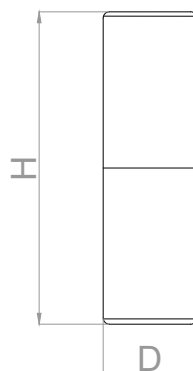

	D [mm]	H [mm]
61.120.K	20	71
61.124.K	24	81
61.127.K	27	91
61.130.K	30	101
61.135.K	35	121
61.140.K	40	121

## Wózek górny 2-rolkowy

Two-wheeled carriage / Doppelführungsrolle / Двухроликсовая каретка

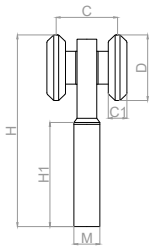

	system	M	D [mm]	C [mm]	C1 [mm]	H [mm]	H1 [mm]
60.500.25	25	M8	25	20	6	71,5	39
60.500.44	44	M12	44	22	11	124	68

## Wózek górny 4-rolkowy

Four-wheeled carriage / Vierfachführungsrolle / Четырехроликсовая каретка

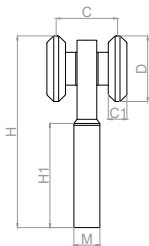

	system	M	D [mm]	C [mm]	C1 [mm]	H [mm]	H1 [mm]
60.510.25	25	M8	25	20	6	71,5	39
60.510.44	44	M12	44	21	11	127	68

## Szyna, długość 3000 mm

Profile guide, length 3000 mm / Profil, Länge 3000 mm / Направляющий профиль, длина 3000 мм

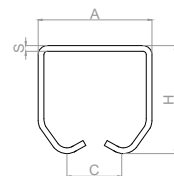

	system	A [mm]	H [mm]	C [mm]	S [mm]
60.520.25	25	35	32	20	2
60.520.44	44	42	54	21	2,5

## Łącznik szyny

Connector for rails / Schienenverbinder / Соединитель

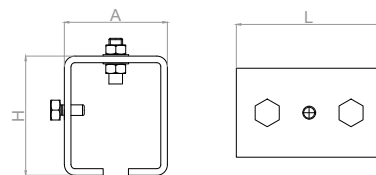

	system	A [mm]	H [mm]	L [mm]
60.521.25	25	41	48	60
60.521.44	44	52	71	60

## Wieszak boczny

Wall fixing bracket / Wandbefestigungswinkel / Настенный крепежный кронштейн

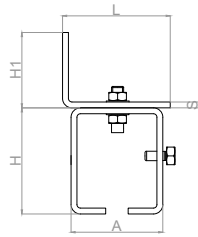

	system	A [mm]	H [mm]	H1 [mm]	L [mm]	S [mm]
60.522.25	25	41	48	50	60	4
60.522.44	44	52	71	50	70	4

## Wieszak górny

Ceiling fixing bracket / Deckenbefestigungsträger / Верхний крепежный кронштейн

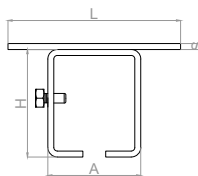

	system	A [mm]	H [mm]	L [mm]	S [mm]
60.523.25	25	41	48	110	4
60.523.44	44	52	72	120	4

## Mocowanie wózka

Adjustable support / Flügelhalterung / Крепежная пластина

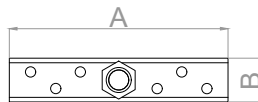

	system	M	A [mm]	B [mm]
60.530.25	25	M8	100	20
60.530.44	44	M12	150	25

## Stoper

Internal stopper / Innenanschlag / Ограничитель



	system
60.535	25, 44



## Rolka jezdna "Y"

Gate wheel "Y" / Führungsrolle "Y" / Ролик "Y"

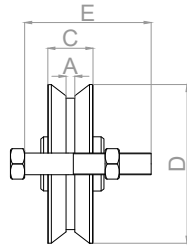

	D [mm]	E [mm]	C [mm]	A [mm]
60.100	68	M10 - 55	20	4,5
60.101	88	M10 - 55	20	4,5

## Rolka jezdna "U"

Gate wheel "U" / Führungsrolle "U" / Ролик "U"

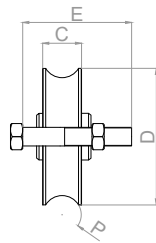

	D [mm]	E [mm]	C [mm]	P [mm]
60.102	68	M10 - 55	20	16
60.103	88	M10 - 55	20	16

## Rolka jezdna "T"

Gate wheel "T" / Führungsrolle "T" / Ролик "T"

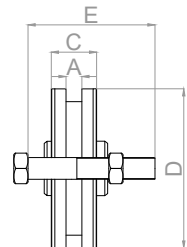

	D [mm]	E [mm]	C [mm]	A [mm]
60.104	68	M10 - 55	20	6,4
60.105	88	M10 - 55	20	7,7

## Klamka z szyldem

Door handle with shield / Türdrücker mit Rosette / Ручка с накладкой

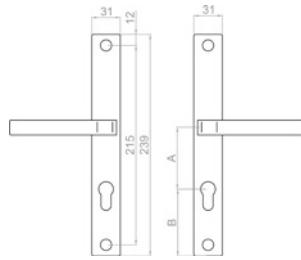

	A [mm]	B [mm]	długość szyldu [mm]	szerokość szyldu [mm]
70.000.72	72	65	239	31
70.000.90	90	67	239	31

## Klamko-pochwyty z szyldem

Door handle and knob with shield / Türdrücker, Griff mit Rosette / Ручка с накладкой

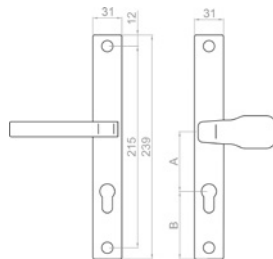

	A [mm]	B [mm]	długość szyldu [mm]	szerokość szyldu [mm]
70.001.72	72	65	239	31
70.001.90	90	67	239	31

## Pochwyty z szyldem

Door knob with shield / Türgriff mit Rosette / Ручка с накладкой

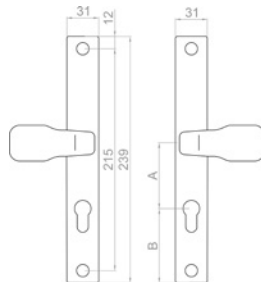

	A [mm]	B [mm]	długość szyldu [mm]	szerokość szyldu [mm]
70.002	72	65	239	31

## Klamka

Door handle / Türdrücker / Дверная ручка

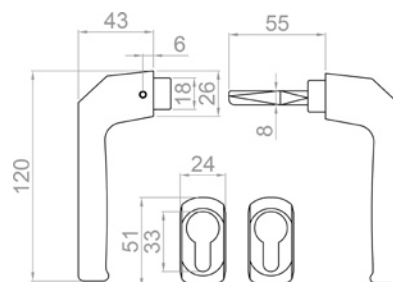

	długość klamki [mm]
70.003	120

## Szyldy plastikowe na wkładkę

Plastic shield / Plastikrosette / Пластиковая накладка

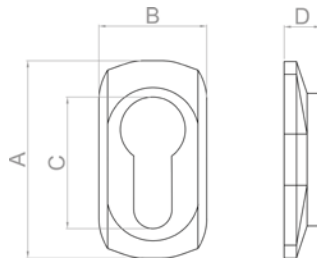

	A [mm]	B [mm]	C [mm]	D [mm]
70.030	51	24	33	8,5

## Zamek zapadkowo-zasuwkowy 22/90

Lock 22/90 / Schloss 22/90 / Врезной замок 22/90

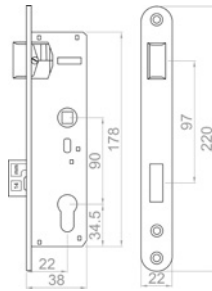

	rozstaw [mm]	szerokość [mm]	głębokość [mm]
70.100	90	22	38

## Zamek zapadkowo-zasuwkowy 34/72

Lock 34/72 / Schloss 34/72 / Врезной замок 34/72

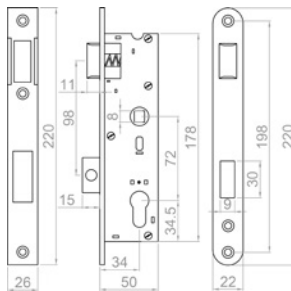

	rozstaw [mm]	szerokość [mm]	głębokość [mm]
70.101	72	34	50

## Zamek rolkowo-zasuwkowy

Lock / Schloss / Врезной замок

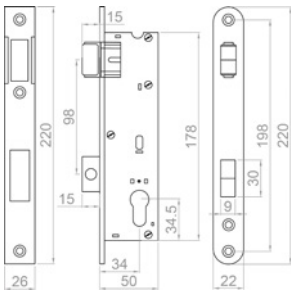

	szerokość [mm]	głębokość [mm]
70.102	22	50

## Zamek hakowy 40

Hooklock 40 / Hakenschloss 40 / Крючковой замок 40

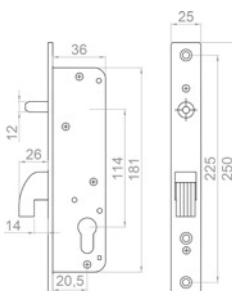

	szerokość [mm]	głębokość [mm]
70.120	25	36

## Zamek hakowy 60

Hooklock 60 / Hakenschlos 60 / Крючковой замок 60

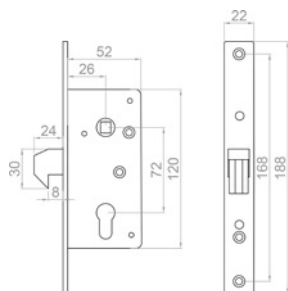

	rozstaw [mm]	szerokość [mm]	głębokość [mm]
70.121	72	22	52

## Zamek hakowy 60/70

Hooklock 60/70 / Hakenschlos 60/70 / Крючковой замок 60/70

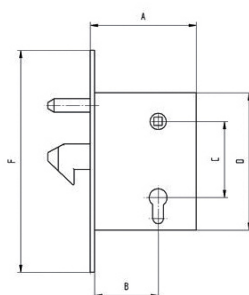

	A [mm]	B [mm]	C [mm]	D [mm]	F [mm]
70.130	100	60	72	130	210

## Kaseta 40 × 40 z zamkiem 90

Box 40 × 40 with lock 90 / Kasten 40 × 40 mit Schloss 90 / Корпус 40 × 40 с врезным замком 90

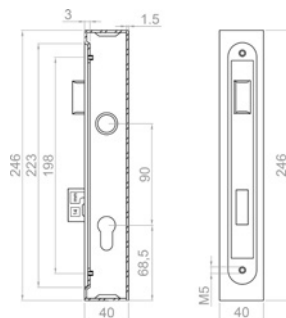

	wysokość [mm]	rozstaw [mm]
70.200	246	90

## Kaseta 40 × 60 z zamkiem 72

Box 40 × 60 with lock 72 / Kasten 40 × 60 mit Schloss 72 / Корпус 40 × 60 с врезным замком 72

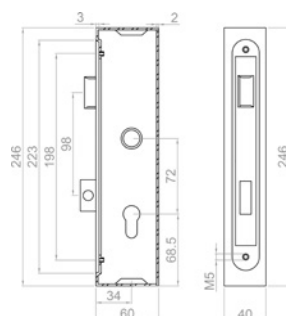

	wysokość [mm]	rozstaw [mm]
70.201	246	72

### Kaseta 30 × 50 z zamkiem 72

Box 30 × 50 with lock 72 / Kasten 30 × 50 mit Schloss 72 / Корпус 30 × 50 с врезным замком 72

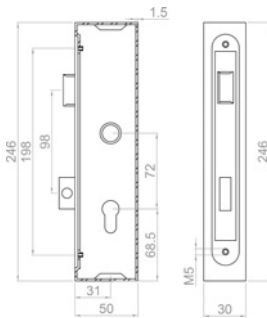

	wysokość [mm]	rozstaw [mm]
70.202	246	72

### Kaseta 40 × 80 ozdobna z zamkiem 50/90

Decorated box 40 × 80 with lock 50/90 / Dekorierter Kasten 40 × 80 mit Schloss 50/90 / Декорированный корпус 40 × 80 с врезным замком 50/90

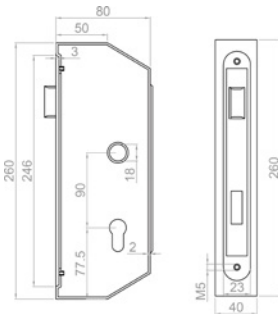

	wysokość [mm]	rozstaw [mm]
70.203	260	90

### Kaseta 40 × 40 z zamkiem hakowym

Box 40 × 40 with hooklock / Kasten 40 × 40 mit Hakenschloss / Корпус 40 × 40 с крючковым замком

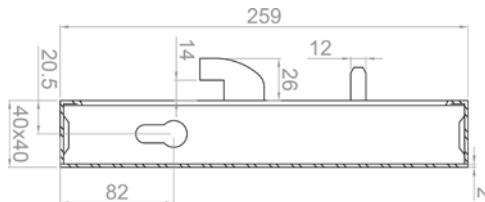

	wysokość [mm]	rozstaw [mm]
70.220	259	-

### Kaseta 40 × 60 z zamkiem hakowym

Box 40 × 60 with hooklock / Kasten 40 × 60 mit Hakenschloss / Корпус 40 × 60 с крючковым замком

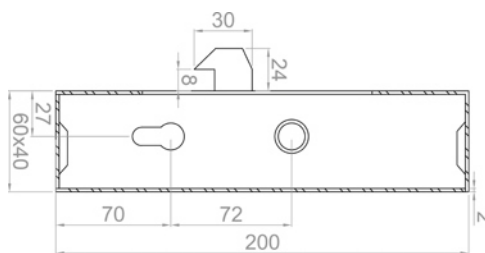

	wysokość [mm]	rozstaw [mm]
70.221	200	72

**Kaseta z profilu 40 × 40**

Box 40 × 40 / Kasten 40 × 40 / Копыц 40 × 40

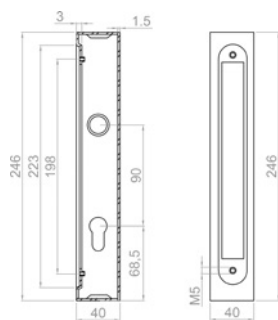

	wysokość [mm]	rozstaw [mm]
70.250	246	90

**Kaseta z profilu 40 × 60**

Box 40 × 40 / Kasten 40 × 40 / Копыц 40 × 40

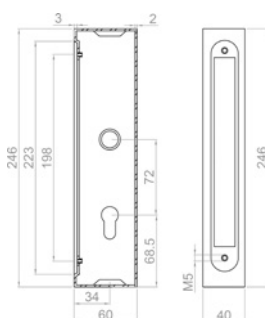

	wysokość [mm]	rozstaw [mm]
70.251	246	72

**Kaseta z profilu 30 × 50**

Box 30 × 50 / Kasten 30 × 50 / Копыц 30 × 50

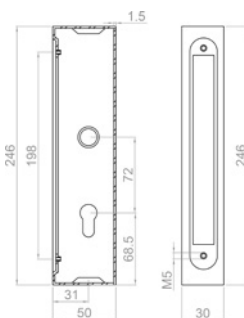

	wysokość [mm]	rozstaw [mm]
70.252	246	72

**Zaczepek furtki dokręcany**

Catch / Anschlag für Schloss / Защелка калитки

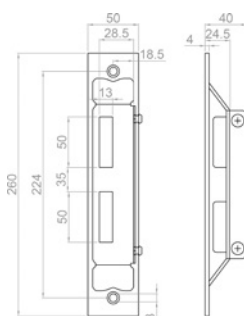

	wysokość [mm]	rozstaw [mm]
70.280	260	50

## Zaczep furtki skrzynkowy

Catch / Anschlag für Schloss / Защелка калитки



	wysokość [mm]	rozstaw [mm]
70.281	292	44,5

## Zaczep furtki

Catch / Anschlag für Schloss / Защелка калитки

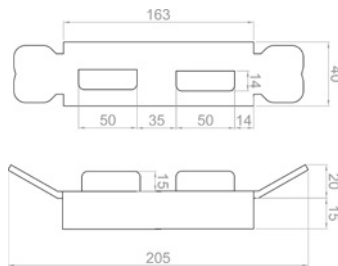

	wysokość [mm]	rozstaw [mm]
70.282	200	40

## Zaczep furtki

Catch / Anschlag für Schloss / Защелка калитки

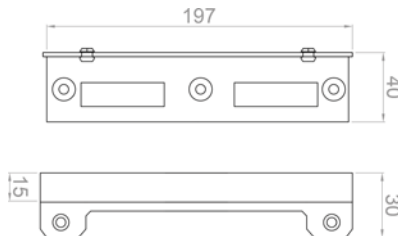

	wysokość [mm]	rozstaw [mm]	wykończenie
70.283	197	40	ocynk
70.283.01	197	40	antracyt 7016

## Zaczep furtki

Catch / Anschlag für Schloss / Защелка калитки

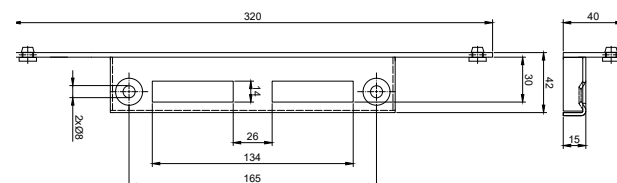

	wysokość [mm]	rozstaw [mm]	wykończenie
70.290	320	42	ocynk
70.290.7016	320	42	antracyt
70.290.9005	320	42	czarny



## Wkładka mosiężna

Lock / Schloseinsatz / Цилиндр замка



	wymiar [mm]
70.300.25	25 × 25
70.300.30	30 × 30
70.300.35	35 × 35

## Wkładka niklowana

Lock / Schloseinsatz / Цилиндр замка



	wymiar [mm]
70.301.25	25 × 25
70.301.30	30 × 30
70.301.35	35 × 35

## Kaseta elektrozaczepu

Electric lock box / Schlosskasten für elektrische Türöffner / Корпус электромагнитной защелки

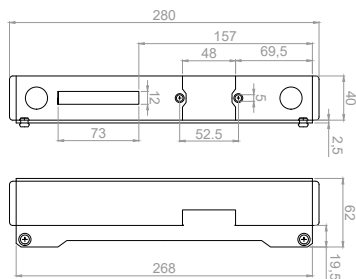

	wysokość [mm]	wykończenie
70.600	280	ocynk
70.600.01	280	antracyt 7016

## Kaseta elektrozaczepu długa

Electric lock box / Schlosskasten für elektrische Türöffner / Корпус электромагнитной защелки

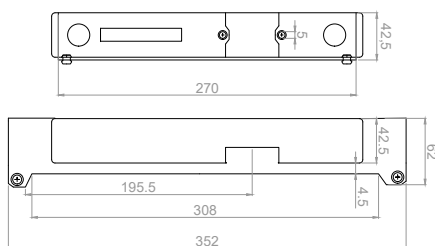

	wysokość [mm]	wykończenie
70.601	352	ocynk
70.601.01	352	antracyt 7016

## Blacha czołowa

Faceplate / Schliessblech / Лицевая панель

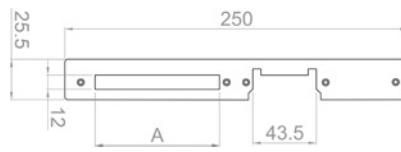

	wysokość [mm]	A [mm]	wykończenie
70.610	250	77,5	malowana / szary
70.611	250	102	O cynk

## Elektrozaczep

Electric lock / Elektrische Türöffner / Электромагнитная защелка



	wersja
70.650	podstawowa
70.651	pamięć, blokada
70.652	pamięć, blokada, regulacja

## Rygiel czarny

Black latch / Schwarzer Riegel / Черный ригель

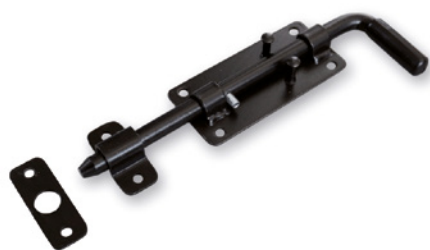

	dlugość [mm]
73.000	220
73.001	420

## Rygiel wąski ocynkowany

Galvanized latch / Verzinkter Riegel / Оцинкованный ригель узкий



	dlugość [mm]
73.010	220
73.011	420

## Rygiel wąski niemalowany

Unpainted latch / Unlackierter Riegel / Неокрашенный ригель узкий



	dlugość [mm]
73.012	420

## Rygiel ze sprężyną ocynkowany

Galvanized latch with spring / Verzinkter Riegel mit Feder / Оцинкованный ригель с пружиной



	dlugość [mm]
73.020	220
73.021	420

## Rygiel z uchwytem ocynkowany

Galvanized latch with handle / Verzinkter Riegel mit Griff / Оцинкованный ригель с рукояткой



	dlugość [mm]
73.030	800

## Zasuwa ocynkowana

Galvanized latch / Verzinkter Riegel / Оцинкованная задвижка



	dlugość [mm]
73.102	270
73.103	340

## Zasuwa ocynkowana

Galvanized latch / Verzinkter Riegel / Оцинкованная задвижка



	dlugość [mm]
73.104	210

## Zasuwa ocynkowana

Galvanized latch / Verzinkter Riegel / Оцинкованная задвижка



	dlugość [mm]
73.110	270

## Zasuwa wąska

Latch / Riegel / Узкая задвижка



	dlugość [mm]	wykończenie
73.111	340	niemalowana
73.112	340	ocynk

## Zasuwa ocynkowana

Galvanized latch / Verzinkter Riegel / Оцинкованная задвижка



	dlugość [mm]
73.160	160
73.161	215

## Zasuwa ocynkowana

Galvanized latch / Verzinkter Riegel / Оцинкованная задвижка



	dlugość [mm]
73.170	108
73.171	127

## Zasuwa ocynkowana

Galvanized latch / Verzinkter Riegel / Оцинкованная задвижка



	dlugość [mm]
73.180	46
73.181	60

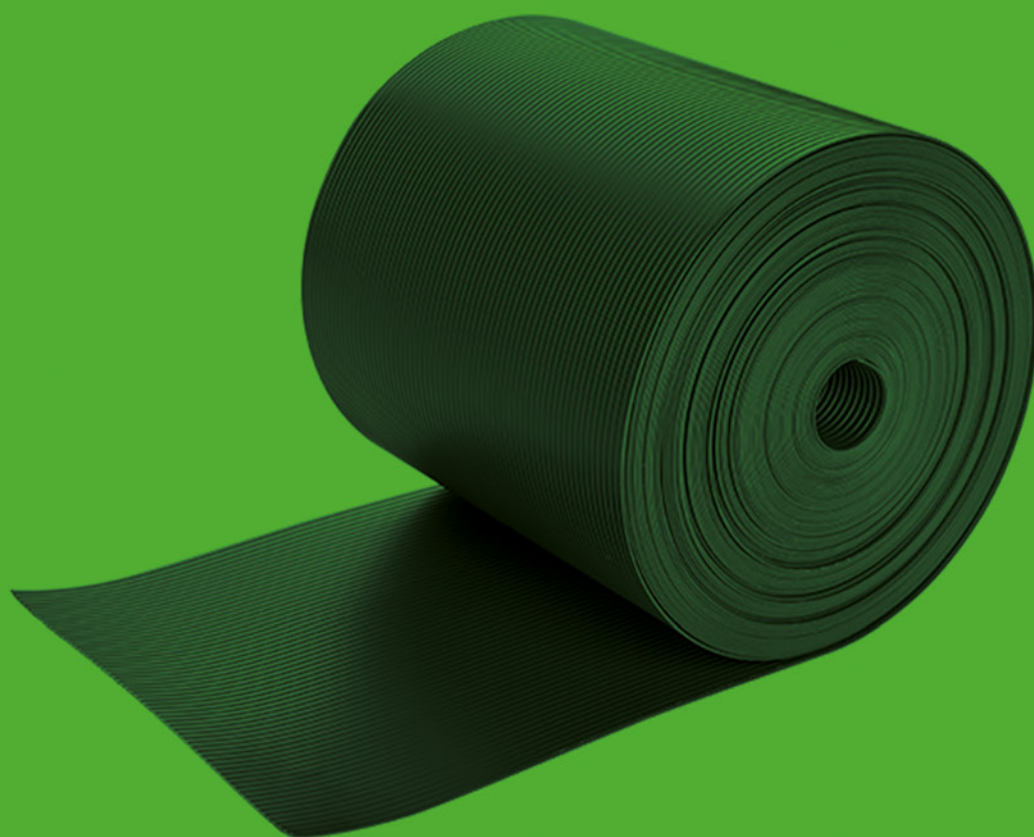

# AKCESORIA OGRODOWE I BALKONOWE

GARDEN AND BALCONY ACCESSORIES  
GARTEN UND BALKON ZUBEHÖR  
САДОВЫЕ И БАЛКОННЫЕ АКЦЕССУАРЫ

2

## TAŚMY OGRODZENIOWE

Nowoczesna taśma ogrodzeniowa WDB PLAST® z podwójnym zabezpieczeniem DUALTECH to innowacyjne rozwiązanie, dzięki któremu możemy stworzyć estetyczny, unikalny i funkcjonalny system ogrodzeniowy.

Taśma WDB PLAST® została wyprodukowana w oparciu o system DUALTECH, co gwarantuje podwyższoną ochronę przed promieniowaniem UV, odbarwianiem koloru i niskimi temperaturami.

Taśma ogrodzeniowa zapewnia poczucie prywatności, chroni przed wiatrem i stanowi skuteczną ochronę prywatności posesji.

Taśma została wykonana z wysokiej jakości tworzywa sztucznego, odpornego na promieniowanie UV, dzięki czemu nie traci swojej pierwotnej barwy.



### ZALETY STOSOWANIA TAŚMY OGRODZENIOWEJ

- ✓ ochrona prywatności  
– taśmy gwarantują dyskrecję i prywatność na posesjach, tarasach, balkonach
- ✓ ochrona przed śniegiem i wiatrem  
– taśmy redukują silne uderzenia wiatru, stanowią zabezpieczenie przed nawiewaniem śniegu na posesje, balkony
- ✓ redukcja hałasu  
– taśmy skutecznie ograniczają hałas w miejscach o dużym natężeniu dźwięku (ruchliwe ulice, place zabaw, place budowy)



### SYSTEM DUALTECH

Oryginalne taśmy ogrodzeniowe marki WDB PLAST® z systemem DUALTECH to innowacyjne rozwiązanie gwarantujące najwyższą jakość produktu.

System DUALTECH składa się z dwóch zabezpieczeń:

- 1. UV STABILIZER** – zapobiega przedwczesnej degradacji materiału, znacząco wydłużając żywotność taśmy ogrodzeniowej marki WDB PLAST®;
- 2. COLOR PROTECT** – chroni taśmę ogrodzeniową przed wyblaknięciem.

Postaw na sprawdzone rozwiązanie!

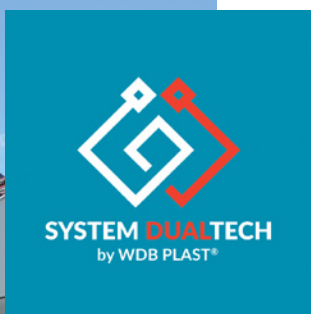

## ZALETY TAŚMY OGRODZENIOWEJ WDB PLAST®

- ✓ posiada certyfikat TÜV SÜD Certification and Testing – badanie pod kątem blaknięcia taśmy, wynik 4/5
- ✓ nie blaknie na słońcu dzięki stabilizacji UV
- ✓ nie odkształca się pod wpływem temperatur
- ✓ nie wymaga konserwacji
- ✓ intuicyjny montaż nie wymaga profesjonalnego sprzętu ani specjalistycznej wiedzy
- ✓ taśma WDB PLAST® PREMIUM LINE wykonana jest z POLIPROPYLENU
- ✓ taśma WDB PLAST® wykonana jest w systemie DUALTECH

Wybierając taśmy ogrodzeniowe marki WDB PLAST® masz pewność otrzymania produktu najwyższej jakości!

## PARAMETRY TAŚM

Rozmiar	190 mm		47,5 mm	
	Premium Line 1,2 mm	Basic Line 450 g	Premium Line 1,2 mm	Basic Line 450 g
Długość 1 rolki	26 mb	35 mb	50 mb	35 mb
Powierzchnia 1 rolki	5 m <sup>2</sup>	6,7 m <sup>2</sup>	2,4 m <sup>2</sup>	1,7 m <sup>2</sup>



## KLIPSY MONTAŻOWE DO TAŚM

Taśma ogrodzeniowa mocowana jest do ogrodzenia za pomocą klipsów montażowych.

Cechy klipsów **WDB PLAST®**:

- ✓ mocny chwyt taśmy,
- ✓ łatwy i szybki montaż,
- ✓ odporność na promieniowanie UV,
- ✓ dostępne w kolorach RAL: 7016, 7040, 8011, 9003, 6005, 9005.

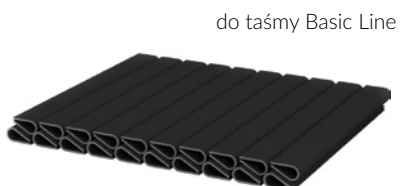

## MONTAŻ TAŚMY OGRODZENIOWEJ

1. Zaplatamy taśmę ogrodzeniową na panel.
2. Mocujemy taśmę w klipsie zakończeniowym.
3. Klips wraz z taśmą ogrodzeniową mocujemy do panelu.

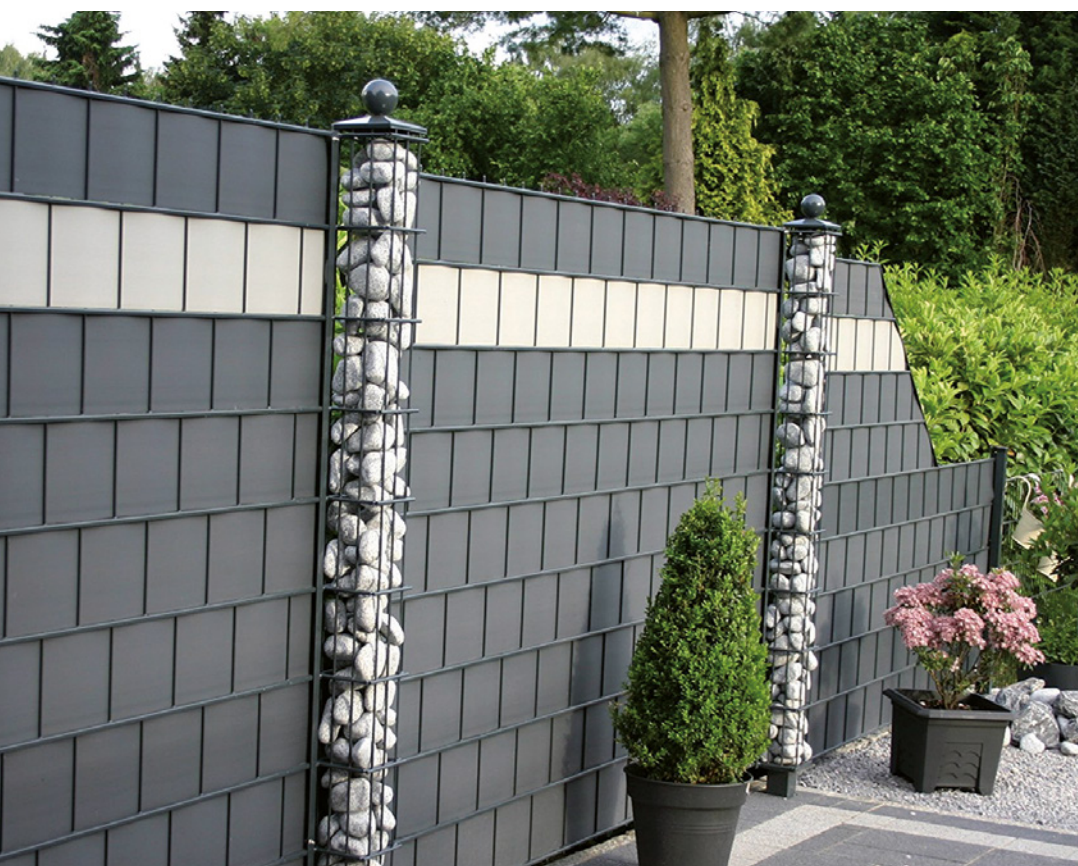
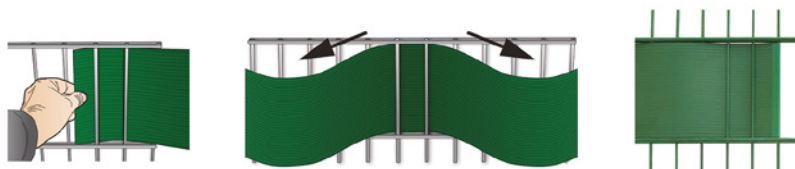

## KOLORY



RAL 7016



RAL 7040



RAL 8011



RAL 9003



RAL 6005



RAL 9005

## TABELE PRZELICZNIKÓW

Poniższe tabele pomogą Ci określić, ile rolek taśmy powinieneś kupić do swojego ogrodzenia. Zmierz najpierw wysokość i szerokość Twoich paneli ogrodzeniowych lub wysokość siatki ogrodzeniowej i jej całkowitą długość, a następnie sprawdź w poniższych tabelach ile rolek potrzebujesz.

### Taśma WDB PLAST® Premium Line i Standard Line 190 mm × 26 m

liczba paneli ogrodzeniowych	rozmiar panela ogrodzeniowego [m]				
	1,00 × 2,50	1,20 × 2,50	1,50 × 2,50	1,80 × 2,50	2,00 × 2,50
	liczba potrzebnych rolek taśmy				
1	1	1	1	1	2
2	2	2	2	2	3
3	2	2	3	3	4
4	3	3	4	4	5
5	3	4	4	5	6
6	4	4	5	6	7
7	4	5	6	7	8
8	5	5	7	8	9
9	5	6	7	9	10
10	6	7	8	10	11

### Taśma WDB PLAST® Basic Line 190 mm × 35 m

liczba paneli ogrodzeniowych	rozmiar panela ogrodzeniowego [m]				
	1,00 × 2,50	1,20 × 2,50	1,50 × 2,50	1,80 × 2,50	2,00 × 2,50
	liczba potrzebnych rolek taśmy				
1	1	1	1	1	1
2	1	1	2	2	2
3	2	2	2	3	3
4	2	2	3	3	4
5	2	3	3	4	4
6	3	3	4	5	5
7	3	4	4	5	6
8	4	4	5	6	7
9	4	5	6	7	7
10	4	5	6	7	8

### Taśma WDB PLAST® Basic Line 190 mm × 50 m

liczba paneli ogrodzeniowych	rozmiar panela ogrodzeniowego [m]				
	1,00 × 2,50	1,20 × 2,50	1,50 × 2,50	1,80 × 2,50	2,00 × 2,50
	liczba potrzebnych rolek taśmy				
1	1	1	1	1	1
2	1	1	1	1	2
3	1	1	2	2	2
4	2	2	2	2	3
5	2	2	2	3	3
6	2	2	3	3	4
7	2	3	3	4	4
8	3	3	4	4	5
9	3	3	4	5	5
10	3	4	4	5	6

### Taśma WDB PLAST® Premium Line i Standard Line 47,5 mm × 50 m (do siatki ogrodzeniowej)

długość siatki [m]	wysokość siatki [m]				
	1,00	1,20	1,50	1,80	2,00
	liczba potrzebnych rolek taśmy				
5	3	3	4	4	5
10	5	6	7	8	9
15	7	8	10	12	13
20	9	11	13	16	17
25	11	13	16	19	22
30	13	16	19	23	26
35	15	18	23	27	30
40	17	21	26	31	34
45	19	23	29	35	38
50	22	26	32	38	43

### Taśma WDB PLAST® Basic Line 47,5 mm × 35 m (do siatki ogrodzeniowej)

długość siatki [m]	wysokość siatki [m]				
	1,00	1,20	1,50	1,80	2,00
	liczba potrzebnych rolek taśmy				
5	4	4	5	6	7
10	7	8	10	11	13
15	10	11	14	17	19
20	13	15	19	22	25
25	16	19	23	28	31
30	19	22	28	33	37
35	22	26	32	38	43
40	25	29	37	44	49
45	28	33	41	49	55
50	31	37	46	55	61

POLYPROPYLENE



## Taśma ogrodzeniowa WDB PLAST® Premium Line

Screening strip WDB PLAST® Premium Line / Zaunsichtschutz WDB PLAST® Premium Line /  
Заборная лента WDB PLAST® Premium Line

kod produktu	kolor [RAL]	wymiary
62.010.7016	antracyt 7016	190 mm × 26 mb
62.010.7040	szary 7040	190 mm × 26 mb
62.010.6005	zielony 6005	190 mm × 26 mb
62.010.8011	brązowy 8011	190 mm × 26 mb
62.010.9003	biały 9003	190 mm × 26 mb
62.010.9005	czarny 9005	190 mm × 26 mb

POLYPROPYLENE

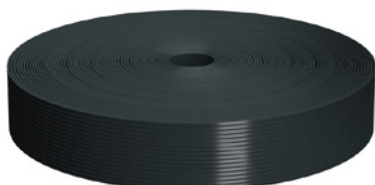

## Taśma ogrodzeniowa WDB PLAST® Premium Line

Screening strip WDB PLAST® Premium Line / Zaunsichtschutz WDB PLAST® Premium Line /  
Заборная лента WDB PLAST® Premium Line

kod produktu	kolor [RAL]	wymiary
62.012.7016	antracyt 7016	47,5 mm × 50 mb
62.012.7040	szary 7040	47,5 mm × 50 mb
62.012.6005	zielony 6005	47,5 mm × 50 mb
62.012.8011	brązowy 8011	47,5 mm × 50 mb
62.012.9003	biały 9003	47,5 mm × 50 mb
62.012.9005	czarny 9005	47,5 mm × 50 mb

PVC 1200 g/m<sup>2</sup>

## Taśma ogrodzeniowa WDB PLAST® Standard Line

Screening strip WDB PLAST® Standard Line / Zaunsichtschutz WDB PLAST® Standard Line /  
Заборная лента WDB PLAST® Standard Line

kod produktu	kolor [RAL]	wymiary
62.000.7016	antracyt 7016	190 mm × 26 mb
62.000.7040	szary 7040	190 mm × 26 mb
62.000.6005	zielony 6005	190 mm × 26 mb
62.000.8011	brązowy 8011	190 mm × 26 mb
62.000.9003	biały 9003	190 mm × 26 mb
62.000.9005	czarny 9005	190 mm × 26 mb

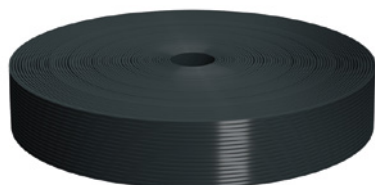
PVC 1200 g/m<sup>2</sup>

## Taśma ogrodzeniowa WDB PLAST® Standard Line

Screening strip WDB PLAST® Standard Line / Zaunsichtschutz WDB PLAST® Standard Line /  
Заборная лента WDB PLAST® Standard Line

kod produktu	kolor [RAL]	wymiary
62.002.7016	antracyt 7016	47,5 mm × 50 mb
62.002.7040	szary 7040	47,5 mm × 50 mb
62.002.6005	zielony 6005	47,5 mm × 50 mb
62.002.8011	brązowy 8011	47,5 mm × 50 mb
62.002.9003	biały 9003	47,5 mm × 50 mb
62.002.9005	czarny 9005	47,5 mm × 50 mb

## Taśma ogrodzeniowa WDB PLAST® Basic Line\*

Screening strip WDB PLAST® Basic Line / Zaunsichtschutz WDB PLAST® Basic Line / Заборная лента WDB PLAST® Basic Line



190 mm × 35 mb	
kod produktu	kolor [RAL]
62.050.7016	antracyt 7016
62.050.7040	szary 7040
62.050.6005	zielony 6005
62.050.8011	brązowy 8011
62.050.9003	biały 9003
62.050.9005	czarny 9005

\* zestaw zawiera 1 rolkę + 20 szt. klipsów

190 mm × 50 mb	
kod produktu	kolor [RAL]
62.070.7016	antracyt 7016
62.070.7040	szary 7040
62.070.6005	zielony 6005
62.070.8011	brązowy 8011
62.070.9003	biały 9003
62.070.9005	czarny 9005

\* zestaw zawiera 1 rolkę + 26 szt. klipsów

PVC 450 g/m<sup>2</sup>

## Taśma ogrodzeniowa WDB PLAST® Basic Line\*

Screening strip WDB PLAST® Basic Line / Zaunsichtschutz WDB PLAST® Basic Line / Заборная лента WDB PLAST® Basic Line

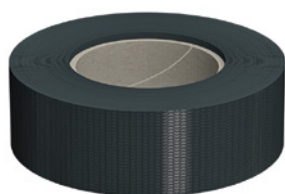

kod produktu	kolor [RAL]	wymiary
62.052.7016	antracyt 7016	47,5 mm × 35 mb
62.052.7040	szary 7040	47,5 mm × 35 mb
62.052.6005	zielony 6005	47,5 mm × 35 mb
62.052.8011	brązowy 8011	47,5 mm × 35 mb
62.052.9003	biały 9003	47,5 mm × 35 mb
62.052.9005	czarny 9005	47,5 mm × 35 mb

\* zestaw zawiera 1 rolkę + 20 sztuk klipsów

PVC 450 g/m<sup>2</sup>

## Klipsy montażowe do taśmy WDB PLAST® (uniwersalne)

Fitting clips for strip WDB PLAST® (universal) / Clipse für Sichtschutz WDB PLAST® (Universal) / Монтажные клипсы для ленты WDB PLAST® (Универсальный)



wysokość 190 mm

kod produktu	kolor [RAL]
62.001.7016	antracyt 7016
62.001.7040	szary 7040
62.001.6005	zielony 6005
62.001.8011	brązowy 8011
62.001.9003	biały 9003
62.001.9005	czarny 9005

wysokość 47,5 mm

kod produktu	kolor [RAL]
62.003.7016	antracyt 7016
62.003.7040	szary 7040
62.003.6005	zielony 6005
62.003.8011	brązowy 8011
62.003.9003	biały 9003
62.003.9005	czarny 9005

## Klipsy montażowe do taśmy WDB PLAST® Basic Line

Fitting clips for strip WDB PLAST® Basic Line / Clipse für Sichtschutz WDB PLAST® Basic Line / Монтажные клипсы для ленты WDB PLAST® Basic Line



wysokość 190 mm

kod produktu	kolor [RAL]
62.051.7016	antracyt 7016
62.051.7040	szary 7040
62.051.6005	zielony 6005
62.051.8011	brązowy 8011
62.051.9003	biały 9003
62.051.9005	czarny 9005

wysokość 47,5 mm

kod produktu	kolor [RAL]
62.053.7016	antracyt 7016
62.053.7040	szary 7040
62.053.6005	zielony 6005
62.053.8011	brązowy 8011
62.053.9003	biały 9003
62.053.9005	czarny 9005

## OSŁONY BALKONOWE

Kolejnym rozwiązaniem zapewniającym poczucie prywatności na balkonach i tarasach jest dedykowana do balustrad osłona balkonowa WDB PLAST®.

Osłona balkonowa została wykonana z wysokiej jakości tworzywa odpornego na wilgoć oraz wysokie i niskie temperatury, dzięki czemu charakteryzuje się zwiększoną żywotnością i wytrzymałością.

Osłona balkonowa to wysoce funkcjonalne rozwiązanie:

- ✓ osłania balkony i tarasy od wzroku przechodniów i sąsiadów,
- ✓ zabezpiecza przed nawiewaniem zanieczyszczeń z zewnątrz (np. kurzu, liści, śniegu),
- ✓ zatrzymuje silne podmuchy wiatru,
- ✓ zapewnia zacienienie,
- ✓ uniemożliwia zwierzętom przedostanie się przez balustradę.



## OBRZEŻA TRAWNIKOWE

Obrzeża trawnikowe WDB PLAST® dają niemal nieograniczone możliwości planowania, kształtowania i porządkowania powierzchni ogrodowej.

Wykorzystanie obrzeży pozwala na tworzenie oryginalnych i unikalnych kompozycji ogrodowych, jednocześnie porządkując powierzchnię. Obrzeża ogrodowe marki WDB PLAST® spełniają swoją rolę także jako rozwiązanie funkcjonalne, pozwalające na stabilne przytwierdzenie do podłoża agrowłókniny lub innych materiałów wykorzystywanych w ogrodnictwie.

Obrzeża wykonane są z elastycznego tworzywa, co pozwala na tworzenie dowolnych kształtów i linii rozgraniczających, a dzięki swojej wytrzymałości na czynniki atmosferyczne, chemiczne oraz mechaniczne, idealnie nadają się do ogrodów prywatnych, jak i parków czy przestrzeni publicznych.

Obrzeża trawnikowe WDB PLAST® zostały wykonane z wysokiej jakości materiału pochodzącego w całości z recyklingu. Obrzeża są przyjazne dla środowiska, a jednocześnie solidne i wytrzymałe – są odporne zarówno na wysokie, jak i niskie temperatury oraz środki chemiczne i środki ochrony roślin.

Obrzeża można łatwo skracać i formować za pomocą podstawowych narzędzi, a mocuje się je do gruntu za pomocą dedykowanych kotew montażowych WDB PLAST®. Gramatura oraz długość kotew pozwala na stabilne umocowanie obrzeża na niemal każdym podłożu. Na obrzeża mogą działać różne siły zewnętrzne, którym kotwy WDB PLAST® stawiają efektywny opór. Dzięki temu możemy zagwarantować zwiększoną żywotność i stateczność konstrukcji.



Zastosowanie obrzeży ogrodowych:

- ✓ kształtowanie trawników,
- ✓ wyznaczanie ścieżek,
- ✓ oddzielanie rabat kwiatowych,
- ✓ tworzenie kompozycji roślinnych i kamienistych,
- ✓ kształtowanie grządek,
- ✓ tworzenie klombów wokół drzew,
- ✓ wydzielenie przestrzeni z korą, grysem itp.

## KRATY TRAWNIKOWE

Kraty trawnikowe WDB PLAST® to idealne rozwiązanie w celu usztywnienia podłoża z jednoczesnym utrzymaniem powierzchni biologicznie czynnej.

Kraty można wypełnić zarówno trawą jak i żwirem lub kamieniem ozdobnym, co pozwoli na osiągnięcie jednocześnie wysokiej funkcjonalności jak i estetycznego sposobu zagospodarowania powierzchni zewnętrznych.



Zastosowanie krat trawnikowych:

- ✓ drogi i podjazdy,
- ✓ parkingi i place,
- ✓ powierzchnie nośne,
- ✓ utwardzenie skarp,
- ✓ wzmocnienie nasypów.



## Siatki cieniujące WDB PLAST®

Hade net WDB PLAST® / Schattiernetz WDB PLAST® / Еневая сетка WDB PLAST®



	kolor	wymiary	zacienienie	liczba opasek zaciskowych
64.090.1525	grafit	1,5 m × 25 mb	90%	100
64.090.1550	grafit	1,5 m × 50 mb	90%	200
64.190.1525	zielony	1,5 m × 25 mb	90%	100
64.190.1550	zielony	1,5 m × 50 mb	90%	200
64.095.1525	grafit	1,5 m × 25 mb	95%	100
64.095.1550	grafit	1,5 m × 50 mb	95%	200

## Agrotkanina WDB PLAST®

Agrotexile WDB PLAST® / Bodengewebe Unkrautfolie WDB PLAST® / Агротекстиль WDB PLAST®





	gramatura	wymiary
64.070.1150	70 g/m <sup>2</sup>	1,1 m × 50 mb
64.070.1550	70 g/m <sup>2</sup>	1,5 m × 50 mb
64.071.1150	90 g/m <sup>2</sup>	1,1 m × 50 mb
64.071.1550	90 g/m <sup>2</sup>	1,5 m × 50 mb

## Ostona balkonowa WDB PLAST®

Balcon screen WDB PLAST® / Balkonsichtschutz WDB PLAST® / Балконный экран WDB PLAST®



	kolor [RAL]	wymiary	materiał
62.150.7016	antracyt 7016 	90 cm × 5 mb	technorattan
62.150.7040	szary 7040 	90 cm × 5 mb	technorattan

## Ostona balkonowa WDB PLAST®

Balcon screen WDB PLAST® / Balkonsichtschutz WDB PLAST® / Балконный экран WDB PLAST®



	kolor	wymiary	materiał
62.160.095	szary 	90 cm × 5 mb	HDPE
62.160.094	szary 	90 cm × 4 mb	HDPE
62.160.105	szary 	100 cm × 5 mb	HDPE
62.160.104	szary 	100 cm × 4 mb	HDPE

## Obrzeże trawnikowe WDB PLAST® Eco Border

Garden edge WDB PLAST® Eco Border / Garteneinfassung WDB PLAST® Eco Border / Садовый бордюр WDB PLAST® Eco Border





kod produktu	kolor [RAL]	wymiary
62.170.6005	zielony 6005 	4 cm × 10 mb
62.170.8011	brązowy 8011 	4 cm × 10 mb
62.170.9005	czarny 9005 	4 cm × 10 mb

## Obrzeże trawnikowe WDB PLAST® Pro Border

Garden edge WDB PLAST® Pro Border / Garteneinfassung WDB PLAST® Pro Border / Садовый бордюр WDB PLAST® Pro Border



kod produktu	kolor [RAL]	wymiary
62.180.9005	czarny 9005 	45 mm × 1 mb
62.181.9005	czarny 9005 	55 mm × 1 mb
62.182.9005	czarny 9005 	78 mm × 4 mb

## Kotwy do agrotkaniny

Anchors for agrotex / Anker für Bodengewebe Unkrautfolie / Анкеры для агротекстиля



kod produktu	wykończenie	wymiary [mm]	opakowanie
62.183	ocynk	150 × 25 × 2,9	100 szt.



kod produktu	wykończenie	długość [mm]	opakowanie
62.184	czarny	150	50 szt.

## Kotwa do obrzeży trawnikowych

Anchor for garden edges / Anker für Garteneinfassungen / Анкер для садовых бордюров







kod produktu	kolor [RAL]	długość
62.185.9005	czarny 9005 	18 cm

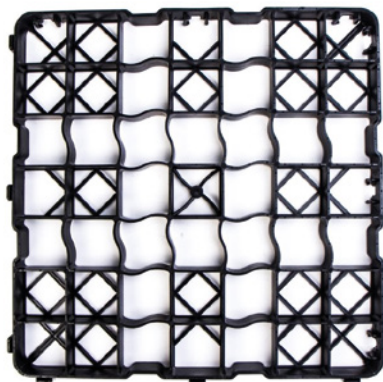

## Krata trawnikowa WDB PLAST® Pro

Grass paver WDB PLAST® Pro / Rasengitter WDB PLAST® Pro / Газонная решетка WDB PLAST® Pro



kod produktu	kolor [RAL]	wymiary [mm]
62.190.30	czarny 9005 	30 × 500 × 500
62.190.40	czarny 9005 	40 × 500 × 500
62.190.50	czarny 9005 	50 × 500 × 500

## Krata trawnikowa WDB PLAST® Eco

Grass paver WDB PLAST® Eco / Rasengitter WDB PLAST® Eco / Газонная решетка WDB PLAST® Eco

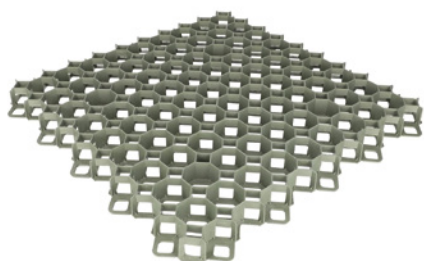







kod produktu	kolor [RAL]	wymiary [mm]
62.195.40	czarny 9005 	40 × 600 × 600
62.196.40	zielony 6005 	40 × 600 × 600

## Znacznik parkingowy do krat trawnikowych

Parking marker for grass pavers / Parkingmarkierung für Rasengitter / Ограничитель парковки для газонных решеток



kod produktu	kolor [RAL]	wymiary [mm]
62.198	antracyt 7016 	ustalane indywidualnie
	szary 7040 	
	zielony 6005 	
	brązowy 8011 	
	biały 9003 	
	czarny 9005 	

## Worek ogrodowy

Garden Waste Bag / Gartensack / Садовая сумка



kod produktu	pojemność [L]	materiał
64.200	272	polipropylen

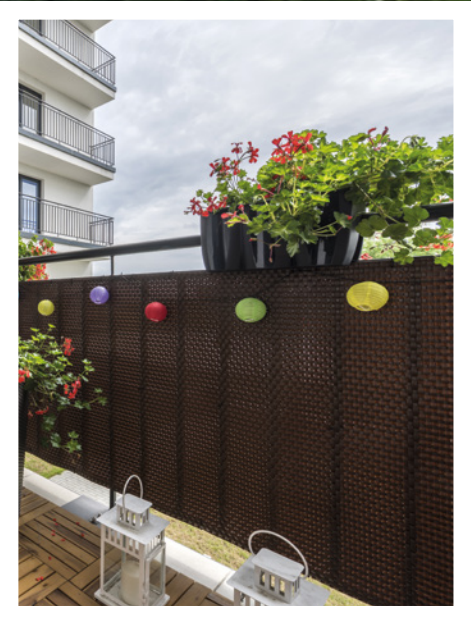



# ZAŚLEPKI PLASTIKOWE

END CAPS  
ABDECKKAPPEN  
ЗАГЛУШКИ

3

## Maskownice śrub i nakrętek

Screw's covers / Abdeckungen der Verschlusskappe / Маскировочные головки

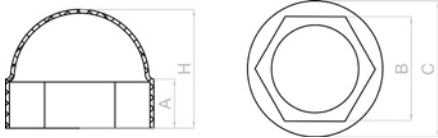

	gwint	B [mm]	C [mm]	H [mm]	A [mm]	klucz
62.600	M5	7,9	10,6	9,5	6	8
62.601	M6	9,9	13,2	13,4	7,3	10
62.602	M8	12,9	17,6	16,5	8,7	13
62.603	M10	16,9	21,6	20,3	10,1	17
62.604	M12	18,9	23,6	21,9	11,4	19
62.605	M14	21,9	27,4	24,2	12,5	22
62.606	M16	23,9	29,6	27,2	14	24
62.607	M18	26,5	33,3	30,3	17,4	27

## Zaślepki do rur okrągłych

End caps / Rohrabdeckungen / Заглушки труб

### metryczne

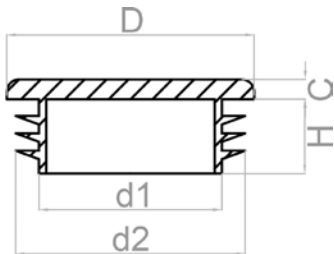

	typ	D [mm]	grubość ścianki [mm]	C [mm]	H [mm]	d1 [mm]	d2 [mm]
62.502	–	16	1,0 – 1,5	5	12,7	10,3	15
62.503	–	18	1,0 – 1,5	5	14,3	12,4	17
62.504	–	20	1,0 – 1,5	4,2	12,5	13,5	18,5
62.506	–	25	1,0 – 2,0	4,2	13	17,6	23,4
62.509	–	30	1,0 – 2,0	5	15	25	29
62.510	–	32	1,0 – 2,0	5	15	25,3	30
62.511	–	35	1,0 – 2,0	5	15,2	25,8	32,8
62.513	–	40	1,5 – 2,5	5	15	32	38,8
62.530	–	45	1,0 – 2,5	5	14,9	34,5	43,5
62.515	–	50	1,2 – 2,5	5	18	42,5	48,5
62.516	–	60	1,5 – 3,0	5	19,5	50,9	58,4
62.517	–	70	1,5 – 4,0	5	22,1	59	67,2
62.518	–	76	1,5 – 2,5	5	21,8	64	74

### calowe

	typ	D [mm]	grubość ścianki [mm]	C [mm]	H [mm]	d1 [mm]	d2 [mm]
62.531	ZO ½"	21,3	2,5 – 3,5	4,6	14,3	12,5	16,8
62.532	ZO ¾"	26,9	2,0 – 3,2	5	20	19,4	23,4
62.533	ZO 1"	33,7	2,5 – 3,2	5	20	24,8	28,5
62.534	ZO 1¼"	42,4	1,5 – 3,6	5	15	33,5	40,8
62.535	ZO 1½"	48,3	2,0 – 3,6	5	17,5	37,8	45,5
62.536	ZO 2"	60,3	2,0 – 3,6	5	18	49	57,6
62.537	ZO 2½"	76	3,0 – 4,0	5	22	63,7	71,3
62.538	ZO 3"	90	3,0 – 5,0	5	21	76,9	86,3

## Zaśleпки do profilu prostokątnego

End caps / Torprofilabdeckungen / Заглушки профиля

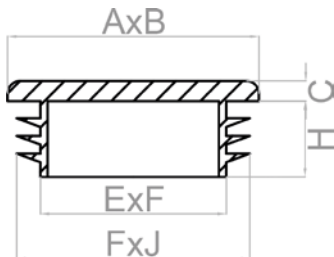

	A × B [mm]	grubość ścianki [mm]	C [mm]	H [mm]	E × F [mm]	F × J [mm]
62.400	10 × 20	0,8 - 1,0	3	12	6,1 × 15,9	9,0 × 19,3
62.405	15 × 25	1,0 - 2,0	5	12,9	10,3 × 19,9	13,9 × 23,9
62.408	18 × 30	1,0 - 3,0	5	14	11,0 × 22,6	16,5 × 28,5
62.409	20 × 30	1,0 - 3,0	5	14	13,0 × 22,5	18,5 × 28,5
62.410	20 × 40	1,0 - 3,0	5	14	13,0 × 32,6	18,5 × 38,5
62.411	20 × 50	1,0 - 3,0	5	15	13,0 × 42,8	18,7 × 49,0
62.412	20 × 60	1,5 - 3,0	5	14	14,0 × 54,0	18,2 × 58,0
62.442	20 × 80	1,5 - 3,0	5	17,5	12,9 × 74,3	18,0 × 78,4
62.473	20 × 100	1,5 - 3,0	5	16,9	12,1 × 92,4	18,0 × 98,3
62.413	25 × 40	1,5 - 3,0	5	14	19,8 × 32,5	23,4 × 38,0
62.414	25 × 50	1,5 - 3,0	5	16	15,8 × 40,5	22,8 × 47,2
62.417	27 × 40	1,5 - 3,0	5	14	19,8 × 32,6	25,4 × 38,2
62.418	30 × 40	1,5 - 3,0	5	14	21,7 × 32,4	28,6 × 37,3
62.419	30 × 50	1,5 - 3,0	5	16	22,8 × 42,5	27,6 × 47,5
62.420	30 × 60	1,5 - 3,0	5	16	22,5 × 52,0	27,8 × 58,0
62.427	40 × 60	1,0 - 3,0	5	17	30,8 × 50,5	38,2 × 58,2
62.428	40 × 80	1,5 - 3,0	5	17	28,0 × 68,0	37,6 × 77,2
62.433	50 × 100	2,0 - 4,0	5	20	39,3 × 90,0	46,3 × 95,5
62.435	60 × 80	1,5 - 4,0	5,7	20	46,0 × 66,0	57,5 × 77,1

## Zaśleпки do profilu kwadratowego

End caps / Torprofilabdeckungen / Заглушки профиля

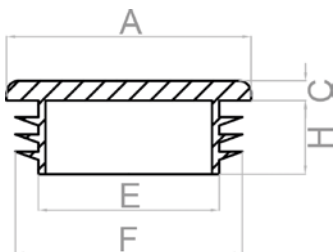

	A × A [mm]	grubość ścianki [mm]	C [mm]	H [mm]	E [mm]	F [mm]
62.301	10 × 10	0,8 - 1,5	3,9	10	5,3	8,9
62.303	15 × 15	1,0 - 2,0	5	12	10	13,4
62.306	20 × 20	1,0 - 2,5	4,2	12,8	13,3	18,6
62.307	25 × 25	1,0 - 2,5	4,4	13	17,6	23,2
62.308	30 × 30	1,0 - 2,5	4,5	14,3	23	28,5
62.310	35 × 35	1,0 - 2,5	5	17	27,1	32,2
62.311	40 × 40	1,2 - 3,0	5	18	31,3	38,4
62.313	45 × 45	1,5 - 3,0	5	17,5	33,5	43,0
62.314	50 × 50	1,5 - 3,0	5	18	43,7	48,0
62.316	60 × 60	1,5 - 3,0	5	18	53	58,3
62.318	70 × 70	1,5 - 4,0	5	21,8	58,5	66,7
62.319	80 × 80	1,5 - 4,5	5	22	67,1	77,4
62.323	90 × 90	2,0 - 5,0	5	25	78,2	87,0
62.320	100 × 100	2,0 - 5,0	5	23	86,3	97,9
62.321	120 × 120	3,0 - 6,5	6,5	28	100,5	115,0
62.324	140 × 140	2,5 - 8,0	7	28,5	120	135,5
62.325	150 × 150	5,0 - 12,0	7	28,5	120	145,2

## Nasadki na słupki ogrodzeniowe okrągłe

End caps / Rohrabdeckungen / Заглушки трубы

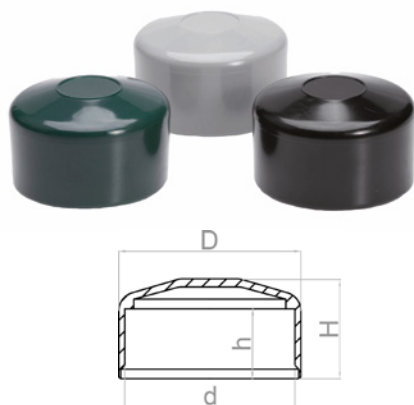

	typ	d [mm]	D [mm]	H [mm]	h [mm]
62.590	NSO 38°	37,8	42,5	29,8	22,5
62.597	NSO 40°	39,8	46,6	29,8	22,5
62.594	NSO 42°	41,7	46,6	34,4	24,4
62.591	NSO 1¼°	42,4	46,8	33,5	24,3
62.595	NSO 44,5°	44,3	48,8	34,5	24,7
62.592	NSO 1½°	48,3	53	33	24
62.596	NSO 51°	50,6	53,3	33	24
62.593	NSO 2°	59,8	65	40	27
62.589	NSO 2½°	75,8	79,5	40	27

## Nasadki na słupki ogrodzeniowe prostokątne

End caps / Rohrabdeckungen / Заглушки трубы

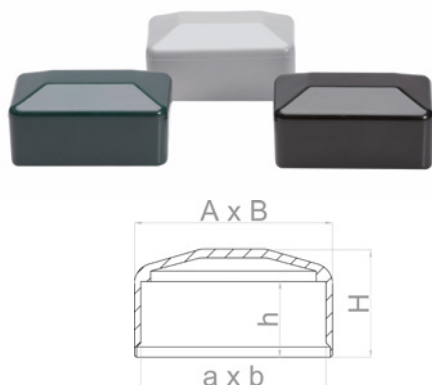

	a × b [mm]	A × B [mm]	H [mm]	h [mm]
62.478	18 × 30	20,5 × 31,0	24	19
62.479	20 × 30	23,5 × 33,5	24	19
62.480	40 × 60	45,0 × 65,0	30,5	21
62.482	40 × 80	45,0 × 85,0	31,2	21,2
62.481	60 × 80	65,0 × 85,0	33	21

## Nasadki na słupki ogrodzeniowe kwadratowe

End caps / Rohrabdeckungen / Заглушки трубы

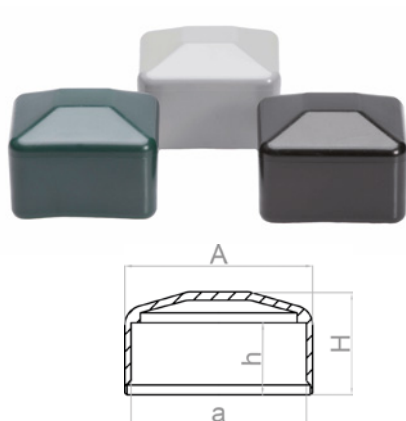

	a × a [mm]	A × A [mm]	H [mm]	h [mm]
62.379	15 × 15	18,7 × 18,7	21	16
62.377	18 × 18	21,6 × 21,6	21,9	17
62.370	20 × 20	24 × 24	24	19
62.378	30 × 30	33,7 × 33,7	19,3	23,8
62.371	40 × 40	45,5 × 45,5	32	21
62.374	50 × 50	54 × 54	27	21
62.372	60 × 60	65 × 65	31	21
62.375	70 × 70	77 × 77	35	25
62.373	80 × 80	87 × 87	36	26
62.376	100 × 100	103 × 103	31	21



# SKRZYNKI NA LISTY

MAIL BOXES  
BRIEFKÄSTEN  
ПОЧТОВЫЕ ЯЩИКИ

4

## Skrzynka klasyczna

Classic box / Klassischer Kästen / Классический ящик



	wymiary [mm]	format korespondencji
65.000	410 × 330 × 102	B4

## Skrzynka klasyczna

Classic box / Klassischer Kästen / Классический ящик



	wymiary [mm]	format korespondencji
65.001	410 × 325 × 102	B4

## Skrzynka klasyczna

Classic box / Klassischer Kästen / Классический ящик



	wymiary [mm]	format korespondencji
65.002	410 × 330 × 102	B4

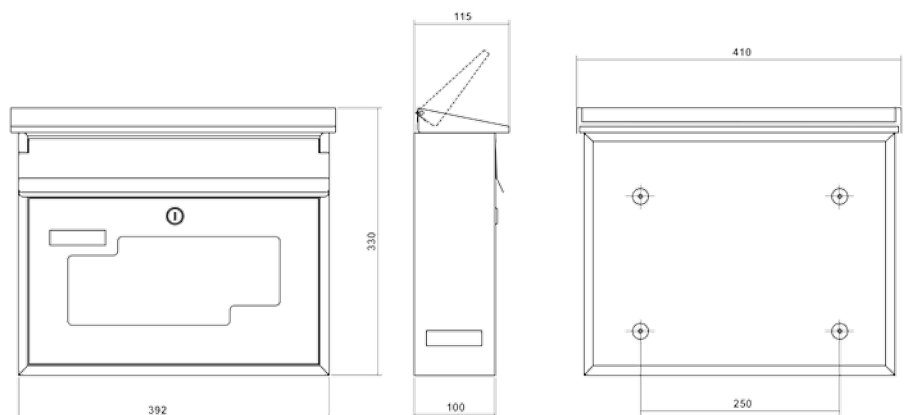



## Skrzynka klasyczna

Classic box / Klassischer Kästen / Классический ящик



	wymiary [mm]	format korespondencji
65.003	410 × 330 × 102	B4

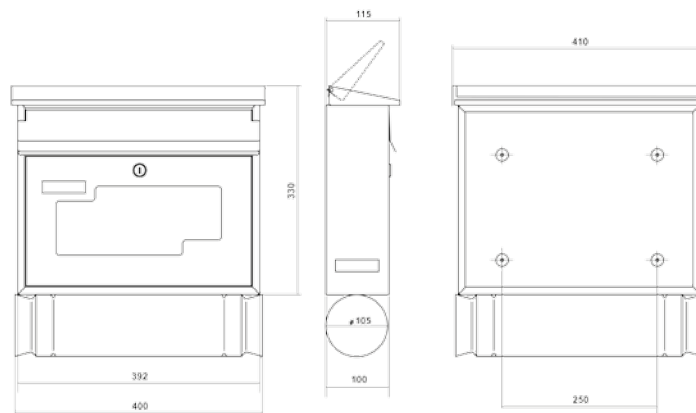

## Skrzynka klasyczna

Classic box / Klassischer Kästen / Классический ящик



	wymiary [mm]	format korespondencji
65.004	410 × 330 × 102	C4

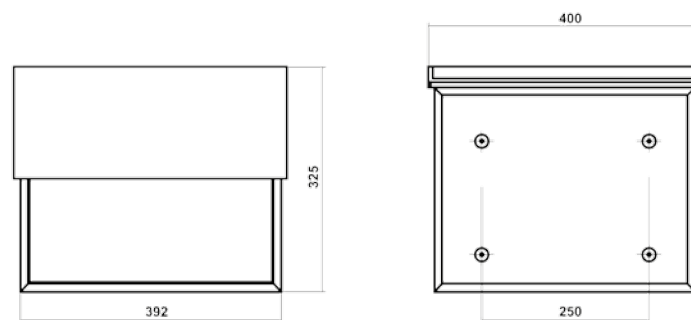

## Skrzynka klasyczna

Classic box / Klassischer Kästen / Классический ящик



	wymiary [mm]	format korespondencji
65.005	410 × 330 × 102	C4

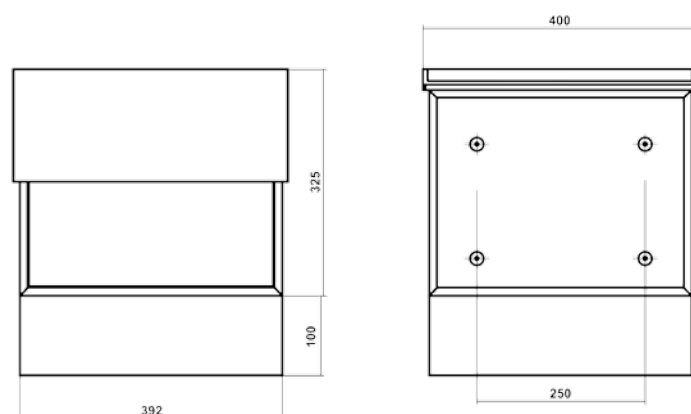

## Skrzynka klasyczna

Classic box / Klassischer Kästen / Классический ящик



	wymiary [mm]	format korespondencji
65.006	265 × 360 × 55	C4

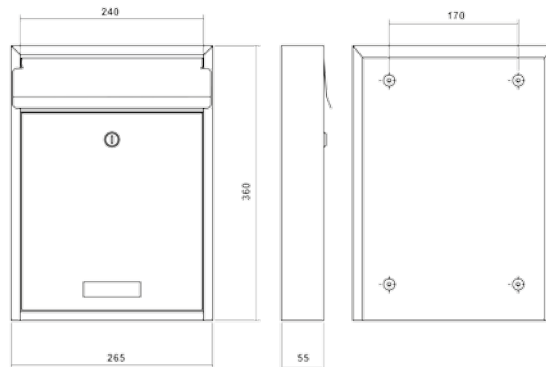

## Skrzynka klasyczna

Classic box / Klassischer Kästen / Классический ящик



	wymiary [mm]	format korespondencji
65.007	265 × 360 × 55	C4

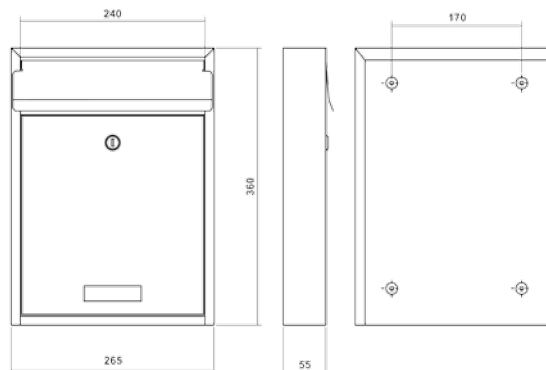

## Skrzynka przelotowa

Through-the-wall mailbox / Mauerdurchwurf Briefkasten / Сквозной почтовый ящик



	wymiary [mm]	format korespondencji
65.200	245 × 260/410	C4

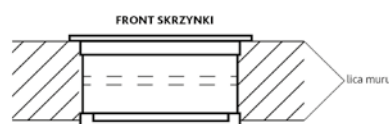
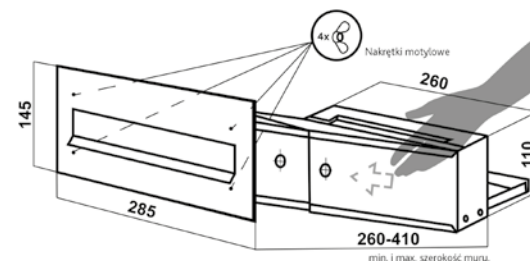

## Skrzynka przelotowa

Through-the-wall mailbox / Mauerdurchwurf Briefkasten / Сквозной почтовый ящик



	wymiary [mm]	format korespondencji
65.201	265 × 360 × 190/255	C4

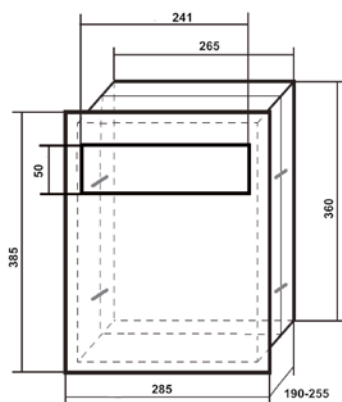

## Skrzynka przelotowa

Through-the-wall mailbox / Mauerdurchwurf Briefkasten / Сквозной почтовый ящик



	wymiary [mm]	format korespondencji
65.202	265 × 360 × 55	C4

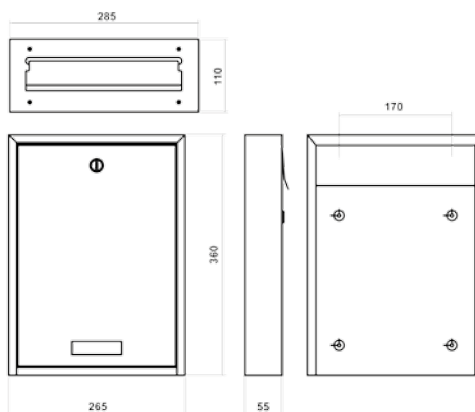

## Skrzynka przelotowa

Through-the-wall mailbox / Mauerdurchwurf Briefkasten / Сквозной почтовый ящик



	wymiary [mm]	format korespondencji
65.203	251 × 360 × 125/195	C4

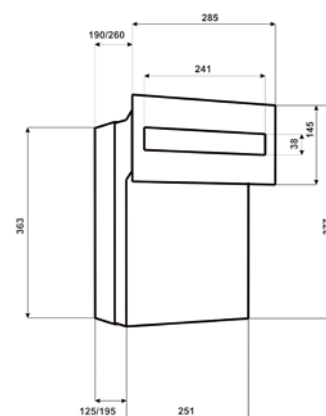

## Skrzynka przelotowa

Through-the-wall mailbox / Mauerdurchwurf Briefkasten / Сквозной почтовый ящик



	wymiary [mm]	format korespondencji
65.204	245 × 260/410	C4

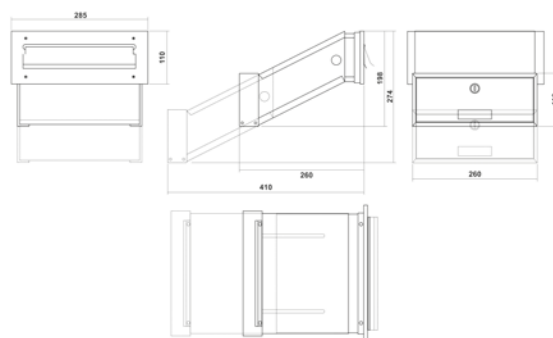

## Skrzynka przelotowa

Through-the-wall mailbox / Mauerdurchwurf Briefkasten / Сквозной почтовый ящик



	wymiary [mm]	format korespondencji
65.100	395 × 306 × 103	C4



## Skrzynka przelotowa

Through-the-wall mailbox / Mauerdurchwurf Briefkasten / Сквозной почтовый ящик



	wymiary [mm]	format korespondencji
65.101	395 × 316 × 103	C4

## Skrzynka domofonowa

Through-the-wall mailbox with an extra shelf and intercom space / Mauerdurchwurf Briefkasten ausziehbar mit Gegensprechanlage / Встраиваемый почтовый ящик с местом на домофон



	wymiary [mm]	format korespondencji
65.400	245 × 260/410	C4

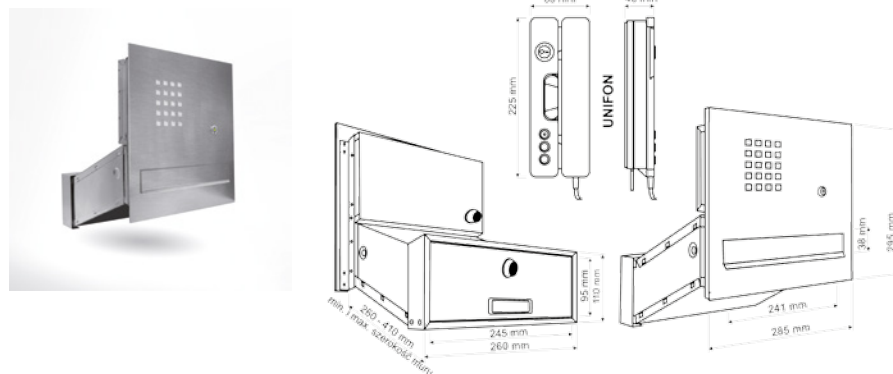

## Skrzynka domofonowa

Through-the-wall mailbox with an extra shelf and intercom space / Mauerdurchwurf Briefkasten ausziehbar mit Gegensprechanlage / Встраиваемый почтовый ящик с местом на домофон



	wymiary [mm]	format korespondencji
65.401	265 × 360 × 190/225	C4

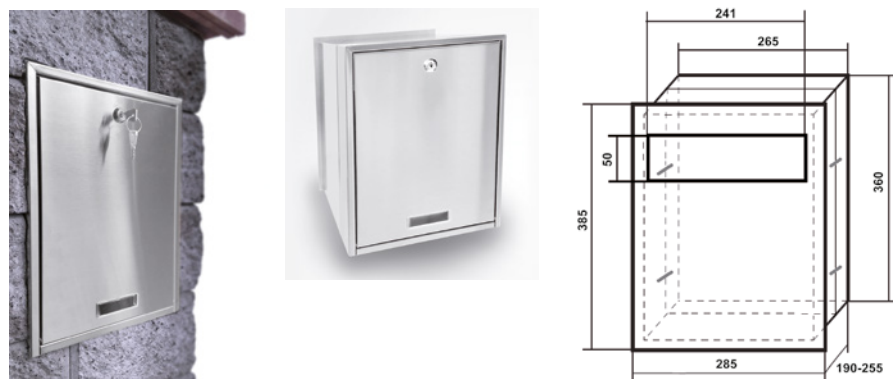

## Skrzynka domofonowa

Through-the-wall mailbox with an extra shelf and intercom space / Mauerdurchwurf Briefkasten ausziehbar mit Gegensprechanlage / Встраиваемый почтовый ящик с местом на домофон



	wymiary [mm]	format korespondencji
65.402	400 × 400 × 160	B4

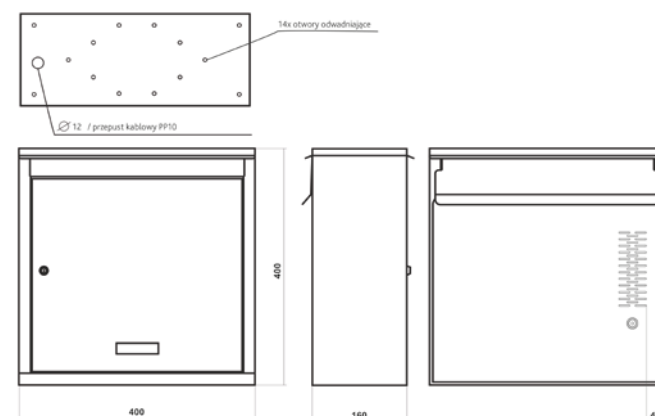

## Skrzynka domofonowa

Through-the-wall mailbox with an extra shelf and intercom space / Mauerdurchwurf Briefkasten ausziehbar mit Gegensprechanlage / Встраиваемый почтовый ящик с местом на домофон



	wymiary [mm]	format korespondencji
65.403	245 × 260/410	C4

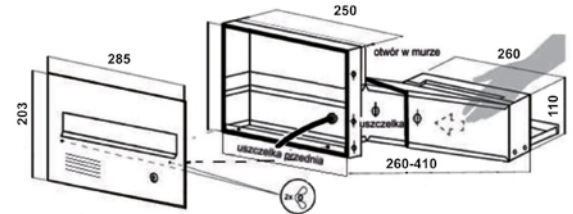

## Skrzynka domofonowa

Through-the-wall mailbox with an extra shelf and intercom space / Mauerdurchwurf Briefkasten ausziehbar mit Gegensprechanlage / Встраиваемый почтовый ящик с местом на домофон



	wymiary [mm]	format korespondencji
65.404	245 × 260/410	C4

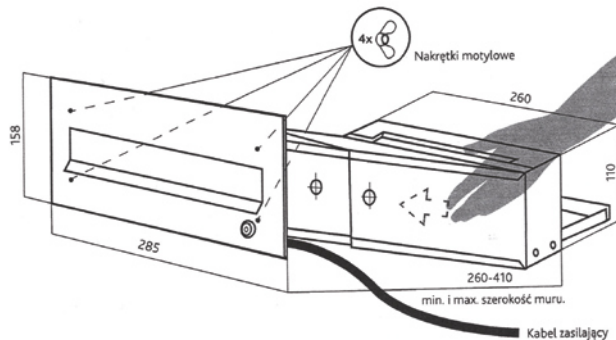

## Skrzynka domofonowa

Through-the-wall mailbox with an extra shelf and intercom space / Mauerdurchwurf Briefkasten ausziehbar mit Gegensprechanlage / Встраиваемый почтовый ящик с местом на домофон



	wymiary [mm]	format korespondencji
65.405	264 × 360 × 190/225	C4

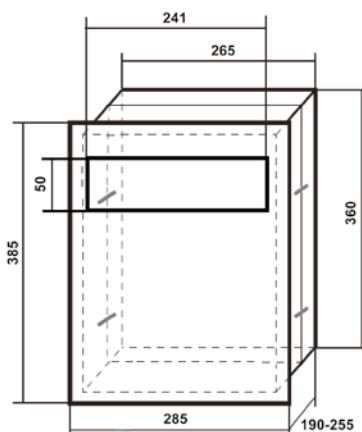

## Skrzynka domofonowa

Through-the-wall mailbox with an extra shelf and intercome space / Mauerdurchwurf Briefkasten ausziehbar mit Gegensprechanlage / Встраиваемый почтовый ящик с местом на домофон



	wymiary [mm]	format korespondencji
65.406	410 × 330 × 102	B4

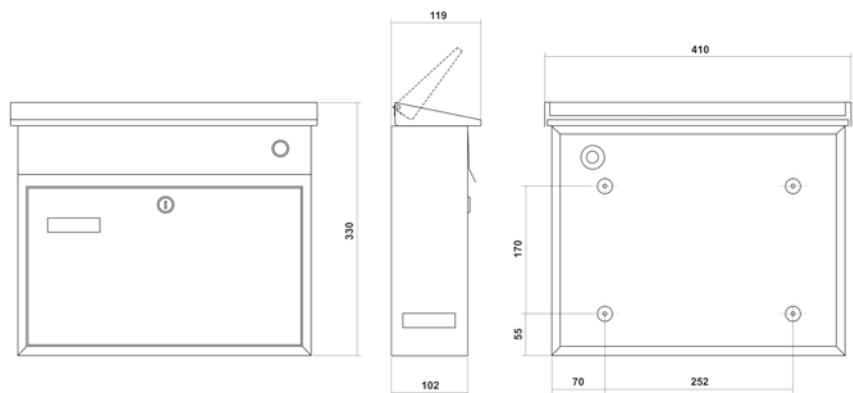

## Litery i cyfry

Letters and Numbers / Buchstaben und Zahlen / Буквы и цифры

**A B C D E**  
**0 1 2 3 4**  
**5 6 7 8 9**

	znak
65.900	A
65.901	B
65.902	C
65.903	D
65.904	E
65.910	0
65.911	1
65.912	2
65.913	3
65.914	4
65.915	5
65.916	6
65.917	7
65.918	8
65.919	9



# TARCZE DO METALU

DISCS  
TRENNSCHEIBEN  
ДИСКИ

5





## Tarcze do cięcia stali + INOX

Cutting discs + INOX / Trennscheiben + INOX / Диски для резки + INOX

TYP 41

typ: płaskie, do przecinania

	wymiary [mm]	1/min (rpm)
CDI.125.10.22	125 × 1,0 × 22,3	12200
CDI.180.20.22	180 × 2,0 × 22,3	8500
CDI.230.20.22	230 × 2,0 × 22,3	6600



## Tarcze zdzierne do stali + INOX

Grinding discs + INOX / Schruppscheiben + INOX / Абразивные диски + INOX

TYP 27

typ: wypukłe

	wymiary [mm]	1/min (rpm)
GDI.125.60.22	125 × 6,0 × 22,3	12200
GDI.230.60.22	230 × 6,0 × 22,3	6600



## Tarcze listkowe do szlifowania stali + INOX

Flap discs + INOX / Lamellenschleifscheiben + INOX / Лепестковые диски для шлифовки стали + INOX

typ: listkowe, wypukłe

	typ	wymiary [mm]	1/min (rpm)
FDI.125.22.40	A40	125 × 22,3	12200
FDI.125.22.60	A60	125 × 22,3	12200
FDI.125.22.80	A80	125 × 22,3	12200

## Tarcze do cięcia stali

Cutting discs / Trennscheiben / Диски для резки

TYP 41 

typ: płaskie, do przecinania



	wymiary [mm]	1/min (rpm)
TC.125.10.22	125 × 1,0 × 22,23	12250
TC.125.16.22	125 × 1,6 × 22,23	12250
TC.125.25.22	125 × 2,5 × 22,23	12250
TC.180.20.22	180 × 2,0 × 22,23	8500
TC.230.20.22	230 × 2,0 × 22,23	8500
TC.300.32.32	300 × 3,2 × 32	5100
TC.350.35.32	350 × 3,5 × 32	4400
TC.400.40.32	400 × 4,0 × 32	3850

## Tarcze do cięcia stali + INOX

Cutting discs + INOX / Trennscheiben + INOX / Диски для резки + INOX

TYP 41 

typ: płaskie, do przecinania



	wymiary [mm]	1/min (rpm)
TCI.125.10.22	125 × 1,0 × 22,23	12250
TCI.125.16.22	125 × 1,0 × 22,23	12250
TCI.230.19.22	230 × 1,9 × 22,23	6650

## Tarcze zdzierne

Grinding discs / Schruppscheiben / Абразивные диски

TYP 27 

typ: z obniżonym środkiem, do szlifowania



	wymiary [mm]	1/min (rpm)
TZ.125.65.22	125 × 6,5 × 22,23	12250
TZ.180.60.22	180 × 6,0 × 22,23	8500
TZ.230.60.22	230 × 6,0 × 22,23	6650

## Tarcze listkowe do szlifowania

Flap discs / Lamenschleifscheiben / Лепестковые диски для шлифовки

typ: listkowe, wypukłe, cyrkonowe



	typ	wymiary [mm]	1/min (rpm)
TL40.125.15.22	A40	125 × 15 × 22,23	12250
TL60.125.15.22	A60	125 × 15 × 22,23	12250
TL80.125.15.22	A80	125 × 15 × 22,23	12250

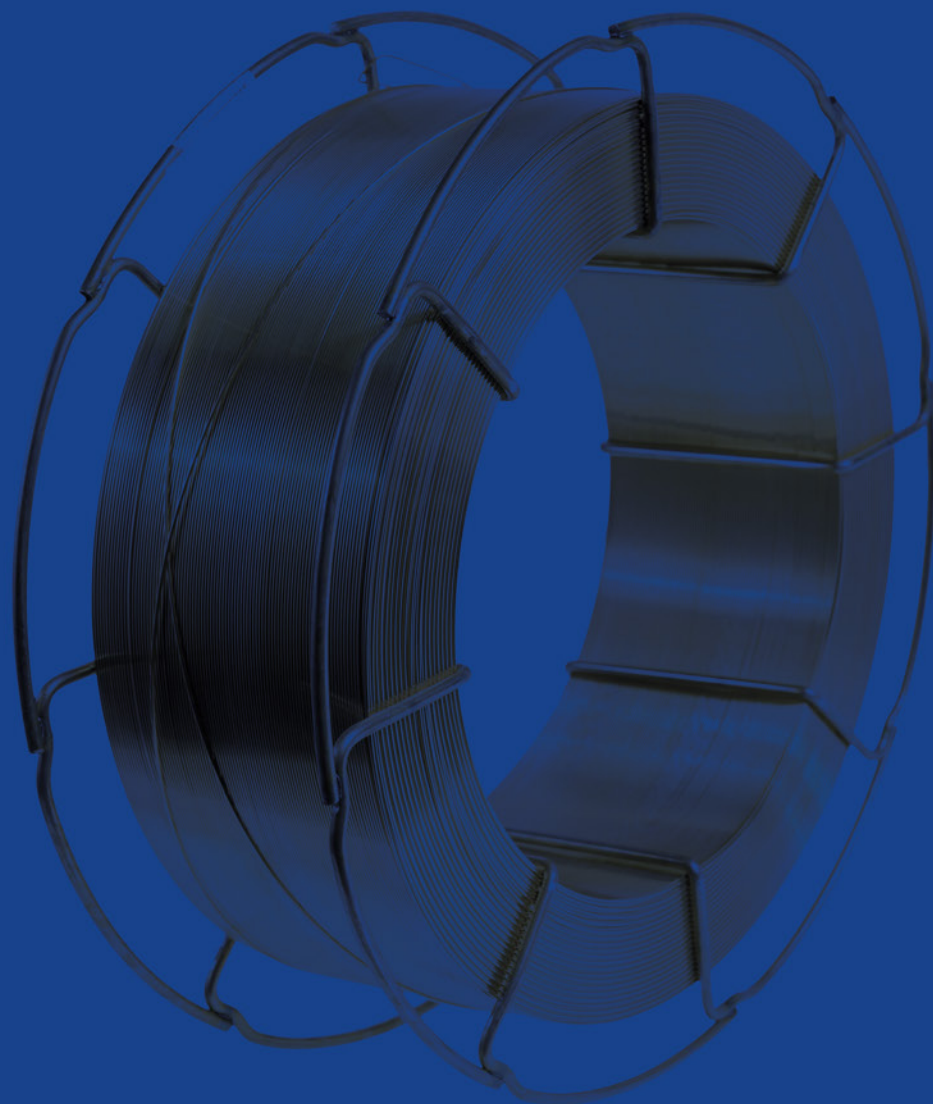

# DRUT SPAWALNICZY

WELDING WIRES  
SCHWEISSDRAHT  
СВАРОЧНАЯ ПРОВОЛОКА



## Drut spawalniczy MIG MAG

MIG MAG welding wire / Schweißdraht MIG MAG / Сварочная проволока MIG MAG



	grubość [mm]	waga [kg]	rodzaj drutu	szpula
DSG.08.15	0,8	15	G3Si1/SG2	D300/metal
DSG.10.15	1,0	15	G3Si1/SG2	D300/metal
DSG.12.15	1,2	15	G3Si1/SG2	D300/metal

## Drut spawalniczy MIG MAG

MIG MAG welding wire / Schweißdraht MIG MAG / Сварочная проволока MIG MAG



	grubość [mm]	waga [kg]	rodzaj drutu	szpula
DSG.08.05	0,8	5	G3Si1/SG2	D200/plastik

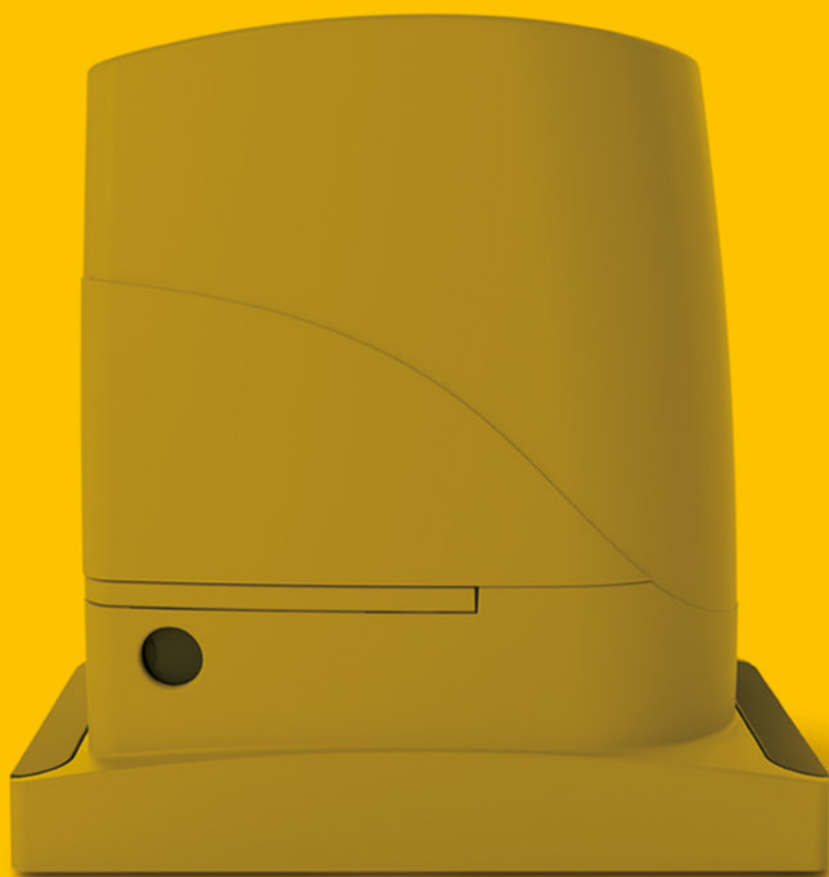

# AUTOMATYKA DO BRAM

AUTOMATION FOR GATES  
TORAUTOMATİK  
АВТОМАТИКА ДЛЯ ВОРОТ

7

Dostarczamy artykuły wiodących producentów automatyki do bram.  
W ofercie posiadamy automatykę do bram przesuwnych i skrzydłowych  
wraz z akcesoriami.

We provide products of the leading gate automation manufacturers. On our offer you will  
find an automation with accessories for swing and sliding gates.

Wir liefern die Artikel der führenden Hersteller von Torantrieben. Im Angebot sind  
Torantriebe für Flügeltore und Schiebetore mit Zuberhöre.

В нашем ассортименте представлена автоматика для ворот ведущих  
производителей. Мы предлагаем автоматику вместе с аксесуарамии для откатных  
и распашных ворот.



The logo for Nice, featuring the word 'Nice' in a white, sans-serif font centered within a solid dark blue square.

The logo for FAAC, featuring the letters 'FAAC' in a bold, black, sans-serif font with a stylized, slanted design.

The logo for CAME, featuring the word 'CAME' in a bold, black, sans-serif font followed by a blue icon consisting of three vertical bars of varying heights and a horizontal bar at the top, resembling a stylized cross or a gate mechanism.



# SYSTEMY DRZWI PRZESUWNYCH

BARN DOOR HARDWARE KIT  
SCHIEBETÜRSYSTEM – BARN DOOR  
РАЗДВИЖНАЯ СИСТЕМА ДЛЯ ДВЕРЕЙ BARN DOOR



## System drzwi przesuwnych BARN DOOR – wzór KLASYCZNY

Sliding door system BARN DOOR – type CLASSIC / Schiebetürsysteme BARN DOOR – typ CLASSIC / Система раздвижных дверей BARN DOOR – тип КЛАССИК



	długość szyny [m]	kolor	akcesoria montażowe
90.001	2	czarny	tak

## System drzwi przesuwnych BARN DOOR – wzór STRZAŁA

Sliding door system BARN DOOR – type ARROW / Schiebetürsysteme BARN DOOR – typ PFEIL / Система раздвижных дверей BARN DOOR – тип СТРЕЛА



	długość szyny [m]	kolor	akcesoria montażowe
90.002	2	czarny	tak

## System drzwi przesuwnych BARN DOOR – wzór T

Sliding door system BARN DOOR – type T / Schiebetürsysteme BARN DOOR – typ T / Система раздвижных дверей BARN DOOR – тип T



	długość szyny [m]	kolor	akcesoria montażowe
90.003	2	czarny	tak



## System drzwi przesuwnych BARN DOOR – wzór PODKOWA

Sliding door system BARN DOOR – type HORSESHOE / Schiebetürsysteme BARN DOOR – typ HUFEISEN / Система раздвижных дверей BARN DOOR – тип ПОДКОВА



	długość szyny [m]	kolor	akcesoria montażowe
90.004	2	czarny	tak

## System drzwi przesuwnych BARN DOOR – wzór PODKOWA LIGHT

Sliding door system BARN DOOR – type HORSESHOE LIGHT / Schiebetürsysteme BARN DOOR – typ HUFEISEN LIGHT / Система раздвижных дверей BARN DOOR – тип ПОДКОВА ЛАЙТ



	długość szyny [m]	kolor	akcesoria montażowe
90.005	2	czarny	tak

## System drzwi przesuwnych BARN DOOR – wzór STANDARD

Sliding door system BARN DOOR – type STANDARD / Schiebetürsysteme BARN DOOR – typ STANDARD / Система раздвижных дверей BARN DOOR – тип СТАНДАРТ



	długość szyny [m]	kolor	akcesoria montażowe
90.006	2	czarny	tak

## System drzwi przesuwnych BARN DOOR – wzór ROMB

Sliding door system BARN DOOR – type RHOMBUS / Schiebetürsysteme BARN DOOR – typ RAUTE / Система раздвижных дверей BARN DOOR – тип РОМБ



	długość szyny [m]	kolor	akcesoria montażowe
90.007	2	czarny	tak

## System drzwi przesuwnych BARN DOOR – wzór LOFT

Sliding door system BARN DOOR – type LOFT / Schiebetürsysteme BARN DOOR – typ LOFT / Система раздвижных дверей BARN DOOR – тип ПОДКОВА ЛОФТ



	długość szyny [m]	kolor	akcesoria montażowe
90.008	2	czarny	tak

## System drzwi przesuwnych BARN DOOR – wzór SMART

Sliding door system BARN DOOR – type SMART / Schiebetürsysteme BARN DOOR – typ SMART / Система раздвижных дверей BARN DOOR – тип УМНАЯ



	długość szyny [m]	kolor	akcesoria montażowe
90.050	3	czarny	tak

## Pochwyt kwadratowy do drzwi przesuwnych 25 × 25 mm

Square knob for sliding door 25 × 25 mm / Quadratischer Türgriff für Schiebetür 25 × 25 mm / Квадратная ручка для раздвижных дверей 25 × 25 мм

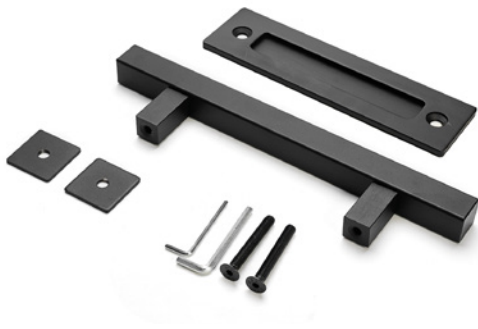

	kolor	wysokość [mm]
90.101	czarny	300

## Pochwyt okrągły do drzwi przesuwnych fi 25 mm

Round knob for sliding door 25 mm / Runder Türgriff für Schiebetür 25 mm / Круглая ручка для раздвижных дверей 25 мм



	kolor	wysokość [mm]
90.102	czarny	300

## Pochwyt kwadratowy do drzwi przesuwnych 15 × 15 mm

Square knob for sliding door 15 × 15 mm / Quadratischer Türgriff für Schiebetür 15 × 15 mm / Квадратная ручка для раздвижных дверей 15 × 15 мм



	kolor	wysokość [mm]
90.103	czarny	300

## Pochwyt do drzwi przesuwnych

Knob for sliding door / Türgriff für Schiebetür / Ручка для раздвижных дверей



	kolor	wysokość [mm]
90.104	czarny	271

## Pochwyty wpuszczany do drzwi przesuwnych

Recessed handle for sliding door / Muschelgriff für Schiebetür / Врезная ручка для раздвижных дверей



	kolor	wysokość [mm]	głębokość [mm]
90.105	czarny	165	13,4

## Prowadzenie dolne do drzwi przesuwnych

Floor guide for sliding door / Bodenführung für Schiebetür / Нижний направляющий элемент для раздвижных дверей



	kolor
90.201	czarny

## Samodomykacz drzwi przesuwnych

Sliding door softopener / Türöffner für Schiebetür / Доводчик для раздвижных двери



	kolor
90.202	czarny



# PLANDEKI

TARPAULINS  
ABDECKPLANEN  
ТЕПТЫ

9

## Plandeka 100 g/m<sup>2</sup>

Tarpaulin / Abdeckplane / Тент

100 g/m<sup>2</sup>

**WDB PLAST®**

### TARPAULIN

- Plandeka
- Abdeckplane
- Bâche de protection
- Protezione PE
- Пленка
- Пленка

Reinforced, all-weather resistant Premium Tarp WDB PLAST® with UV filter provides reliable protection in every conditions for any object. High quality material used guarantees maximum durability, functionality and aesthetic design.

6 × 8 m

100 g/m<sup>2</sup>

8 m (± 5%)
6 m (± 5%)

Waterproof

Frost-resistant

UV Resistant

www.grupawdb.pl



	wymiary [m]	opakowanie zbiorcze [szt.]
10.100.23	2 × 3	20
10.100.33	3 × 3	15
10.100.34	3 × 4	15
10.100.35	3 × 5	12
10.110.44	4 × 4	10
10.100.45	4 × 5	10
10.100.46	4 × 6	8
10.100.48	4 × 8	6
10.100.55	5 × 5	6
10.100.56	5 × 6	6
10.100.58	5 × 8	5
10.100.68	6 × 8	4
10.100.610	6 × 10	1
10.100.810	8 × 10	1
10.100.1012	10 × 12	1
10.100.1015	10 × 15	1

## Plandeka 210 g/m<sup>2</sup>

Tarpaulin / Abdeckplane / Тент

210 g/m<sup>2</sup>

**WDB PLAST®**

### TARPAULIN

- Plandeka
- Abdeckplane
- Bâche de protection
- Protezione PE
- Пленка
- Пленка

Reinforced, all-weather resistant Premium Tarp WDB PLAST® with UV filter provides reliable protection in every conditions for any object. High quality material used guarantees maximum durability, functionality and aesthetic design.

6 × 8 m

210 g/m<sup>2</sup>

8 m (± 5%)
6 m (± 5%)

Waterproof

Frost-resistant

UV Resistant

www.grupawdb.pl



	wymiary [m]	opakowanie zbiorcze [szt.]
10.210.23	2 × 3	10
10.210.33	3 × 3	10
10.210.34	3 × 4	10
10.210.35	3 × 5	8
10.210.44	4 × 4	6
10.210.45	4 × 5	6
10.210.46	4 × 6	5
10.210.48	4 × 8	4
10.210.55	5 × 5	4
10.210.56	5 × 6	4
10.210.58	5 × 8	3
10.210.68	6 × 8	2
10.210.610	6 × 10	1
10.210.810	8 × 10	1
10.210.1012	10 × 12	1
10.210.1015	10 × 15	1

## Plandeka 260 g/m<sup>2</sup>

Tarpaulin / Abdeckplane / Тент

260 g/m<sup>2</sup>



### TARPAULIN

Plandeka  
 Abdeckplane  
 Bâche de protection  
 Protoklone PE  
 Плячка  
 Плячка

Reinforced, all-weather resistant Premium Tarp WDB PLAST® with UV filter provides reliable protection in every conditions for any object. High quality material used guarantees maximum durability, functionality and aesthetic design.

**6 × 8 m**

260 g/m<sup>2</sup>

8 m (± 5%)      6 m (± 5%)

  
 Waterproof

  
 Frost-resistant

  
 UV Resistant

www.grupawdb.pl



	wymiary [m]	opakowanie zbiorcze [szt.]
10.260.23	2 × 3	10
10.260.33	3 × 3	10
10.260.34	3 × 4	6
10.260.35	3 × 5	6
10.260.44	4 × 4	5
10.260.45	4 × 5	4
10.260.46	4 × 6	4
10.260.48	4 × 8	3
10.260.55	5 × 5	3
10.260.56	5 × 6	3
10.260.58	5 × 8	2
10.260.68	6 × 8	2
10.260.610	6 × 10	1
10.260.810	8 × 10	1
10.260.1012	10 × 12	1
10.260.1015	10 × 15	1

## Gumki do plandek (bez haczyków)

Bungee Ball (no hooks) / Planenspanner Ball Bungee (ohne Haken) / Стяжка-петля Ball Bungee (без крючков)

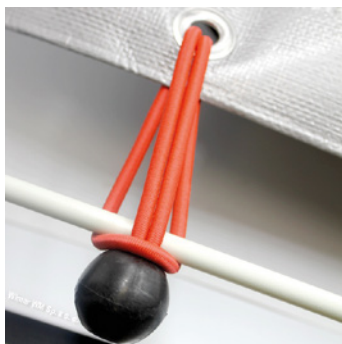

	długość [cm]	opakowanie zbiorcze [szt.]
10.020.10	10	100
10.020.20	20	
10.020.30	30	

## Gumki do plandek (z haczykami)

Bungee Ball (with hooks) / Planenspanner Ball Bungee (mit Haken) / Стяжка-петля Ball Bungee (с крючками)

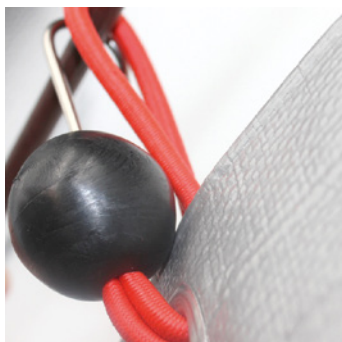

	długość [cm]	opakowanie zbiorcze [szt.]
10.021.10	10	100
10.021.20	20	
10.021.30	30	









Grupa WDB sp. z o.o.  
ul. Feliksa Wrobela 4a  
30-798 Kraków

tel. 517 455 927  
[www.grupawdb.pl](http://www.grupawdb.pl)  
[kontakt@grupawdb.pl](mailto:kontakt@grupawdb.pl)

Grupa WDB sp. z o.o. należy do czołowych dostawców akcesoriów dla domu i ogrodu. Misją firmy jest dostarczanie najwyższej jakości produktów w atrakcyjnych cenach.

Naszymi odbiorcami są głównie firmy produkcyjne i handlowe w kraju oraz za granicą, którym zapewniamy elastyczne warunki współpracy.